



SUPREME

INTERNATIONAL



PULL-TYPE • TRUCK MOUNT • STATIONARY • DELIVERY BOX

SUPREME FOR A REASON

ENGINEERED TO PERFORM



With a history of over 70 Years, SUPREME INTERNATIONAL® was the first company in North America to design, test and manufacture the vertical mixer, and has become the premium manufacturer in the industry. With sizes ranging from 231 to 1,873 ft³, Supreme manufactures mixers custom built for every size of operation that set the bar for quality and innovation.

Based in Wetaskiwin, Alberta, Canada, Supreme is proud to have a dealer network that spans worldwide, providing customers a range of products that are sure to meet their needs and exceed their expectations for quality, durability, and performance.





MANUFACTURED TO LAST



The Supreme vertical mixer is designed to have fewer wear points and a simplicity that gives hassle free maintenance. While other vertical and horizontal mixers may find ways to cut corners or reduce cost, Supreme focuses on quality and craftsmanship.

The tub is designed with sloped walls so feed will slide easily from the top to the floor. Because of the slope there is enough space between the edge of the auger flighting and the tub wall which creates a fast moving volcanic action.

Supreme's mixing tubs have been carefully designed for easier loading, better mixing and longer life. The unobstructed opening facilitates loading of whole bales, regardless of type or size. Thorough mixing is assured because there are no restrictions or dead spots that can hamper material flow in the cutting and mixing process. As a result, material won't grind or tear apart against the sidewalls or in the corners, preserving the quality of your feed. Finally, by eliminating corners, pressure and wear-points on the machine are eliminated, greatly prolonging the life of the unit.

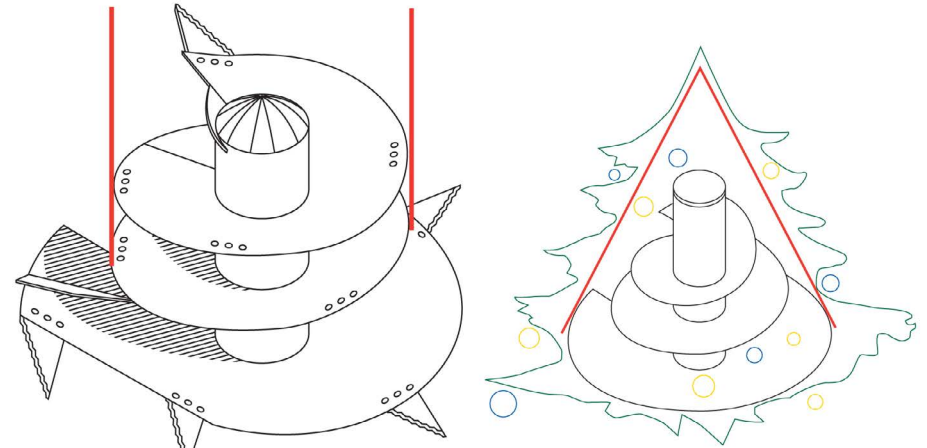

Supreme's Patented Cylindrical Auger vs. competition 'x-mas tree' augers

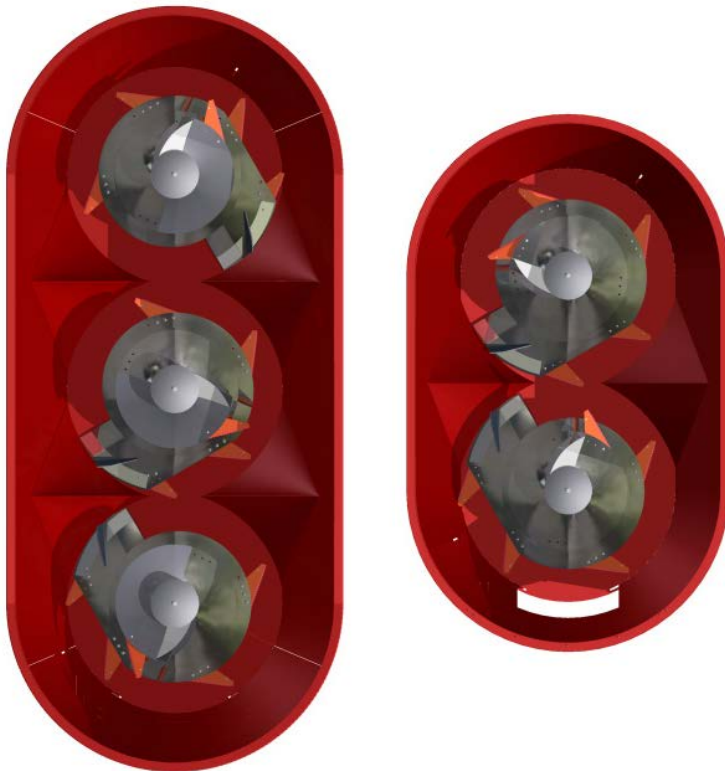

At the heart of a Supreme mixer is Supreme's patented vertical auger design, which delivers incomparable performance with even the most difficult materials yet requires less horsepower to operate than other vertical mixers. You'll be able to process all types, sizes and combinations of bales without the need to pre-shred, pre-process, or break up roughage prior to loading. The free standing vertical auger features four patents that are instrumental in separating the performance of the Supreme from other vertical mixers.

The uniform and wider flighting allows more feed to carry up through the center of the auger to the top. As the auger rotates, it moves feed from the center of the auger outward towards the walls, creating a volcanic effect. When an auger has a Christmas tree or tiered shape like competition mixers, the feed will fall off the flighting before it gets to the top and only the bottom half of the load will get mixed. This is very easy to identify, as there is usually no outward movement or volcanic effect.

If the auger flighting is too wide it will restrict the feed from falling down the sides of the tub, which in turn will slow down the mixing process and/or cause the feed to spill out over the top of the tub.

The specially angled top cutting knife promotes the rapid breakdown of larger bales. The kicker plate directs material to the center of the auger. The cylindrical auger design efficiently moves all materials from the bottom of the tub to the top. The cutaway section on the auger allows feed to fall from the top to the bottom of the tub. These combined features are what produce the volcanic mixing action that quickly and gently blends all materials in the tub.



PULL-TYPE MIXERS

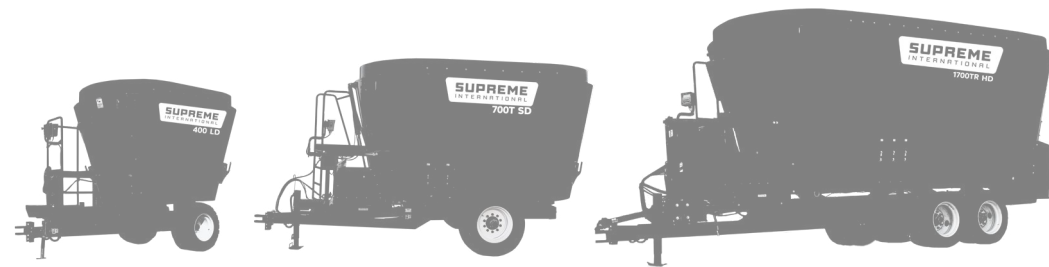



PERFORMANCE, SIMPLICITY AND RELIABILITY

SUPREME INTERNATIONAL® manufactures single, twin and triple auger mixers with sizes ranging from 231-1,873 cubic feet.

Unlike most other vertical mixers that use smaller single stage planetary drives, Supreme uses the heaviest two-stage planetary drive available. Combined with a heavy duty gearbox, this robust system rotates the auger through the toughest of materials. This simple design features few moving parts with no chains, sprockets or countershafts to worry about.

Each Supreme pull-type is built to order with a large variety of options available, ensuring each customer gets a unit that is designed to meet their specific needs.



PRECISION AG MIXER SERIES

Supreme is elevating its premium legacy with the Precision Ag Series.

A purpose-built lineup designed for the real-world needs of today's producers.

The Precision Ag Series brings clarity to a crowded category and helps producers choose with confidence, buy with ease, and operate with purpose. This series is available in Pull-Type, Gen3 TruckMount, Mechanical TruckMount and Stationary models.

LD

LIGHT DUTY CYCLE

The light-duty choice in the lineup is perfect for smaller operations and price-conscious buyers seeking entry-level excellence.

300 - 900T Pull-Types

Configuration:

- Mild Steel Tub Walls
- Supreme Mild Steel Augers
- Supreme Knives
- Supreme Backing Plates
- Robust Planetary Gears

Available Upgrades:

- Auger Magnets

Warranty:

- 2-Year Drivetrain

SD

STANDARD DUTY CYCLE

Our standard mixer is the most versatile option for cow-calf producers and dairy operations mixing feed daily.

All Model Sizes

Configuration:

- Abrasion Resistant Tub Walls
- Supreme Abrasion Resistant Augers
- Supreme Knives
- Supreme Backing Plates
- Oversized Planetary Gears

Available Upgrades:

- Hard-faced Doors & Baffles
- Auger Magnets
- Auger Hard Facing

Warranty:

- 3-Year Drivetrain

HD

HEAVY DUTY CYCLE

The heavy-duty mixer is built for maximum uptime and best suited for larger herds requiring longer mixing cycles.

All Model Sizes

Configuration:

- Abrasion Resistant Tub Walls + 3mm 3CR12 Wall Liner
- Supreme Abrasion Resistant Augers
- Supreme HD Knives
- Supreme Backing Plates
- Oversized Planetary Gears

Available Upgrades:

- Auger Magnets
- Auger Hard Facing
- 3mm Stainless Steel Auger Liners
- 3mm Stainless Steel Tub Floor Liner

Warranty:

- 3-Year Drivetrain

XD

XTREME DUTY CYCLE

Engineered for scale, the XD is the most robust mixer made by Supreme and meets the demands of commercial feeding.

900T and Larger Models

Configuration:

- Abrasion Resistant Tub Walls + 5mm 3CR12 Wall and Floor Liner
- Supreme Abrasion Resistant Xtreme Duty Augers
- Supreme HD Knives
- Supreme HD Backing Plates
- Oversized Planetary Gears
- Auger Magnets

Available Upgrades:

- Auger Hard Facing
- 3mm Stainless Steel Auger Liners

Warranty:

- 3-Year Drivetrain

Purpose-built for today's producers.



AR200 WALLS

SD, HD and XD models feature AR200 which is a high wear steel, much stronger and longer lasting than structural or mild steel.

PROFESSIONAL FINISH

Every Supreme tub and frame are sandblasted and tub seams are professionally finished with an automotive grade paint process.

SCALE SYSTEM

FULL SIZE PLATFORM

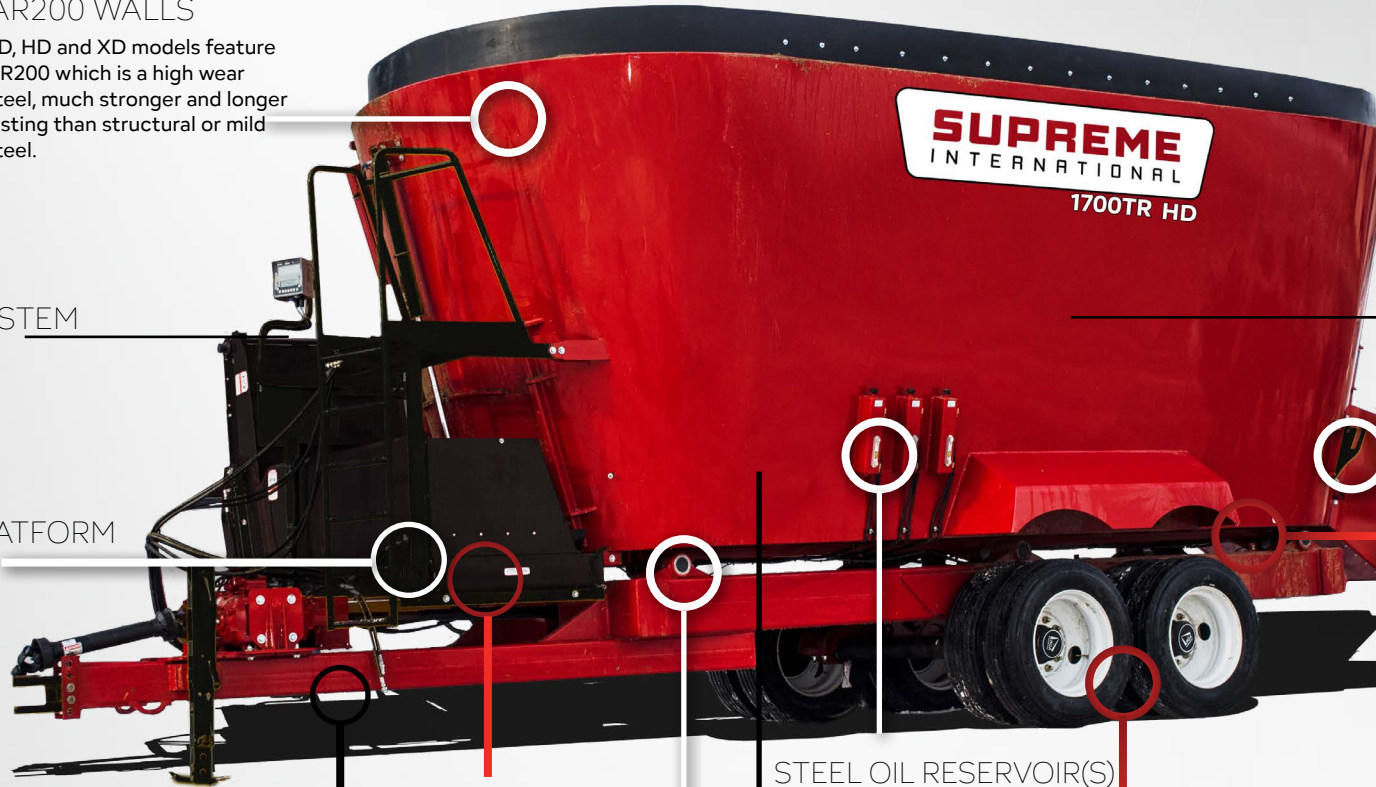

RESTRICTOR PLATES

STRUCTURAL STEEL FLOOR

5/8" on 300 and 400
3/4" on 500 - 900T
1" on 1000T & up

STEEL OIL RESERVOIR(S)

HD CONVEYOR

Supreme conveyors feature 3mm SS top pans, HD roller chain, and high torque orbit motors.

WEIGH BAR SYSTEM

All weighbars are installed under the tub on the frame so that displayed weight is as accurate as possible. The suspended conveyor cradle allows the feed on the conveyor to be included in the weight total.

HIGHWAY TIRES

Standard on most models. Please see spec pages for specific details.

HD TUBULAR FRAME & UNDERCARRIAGE

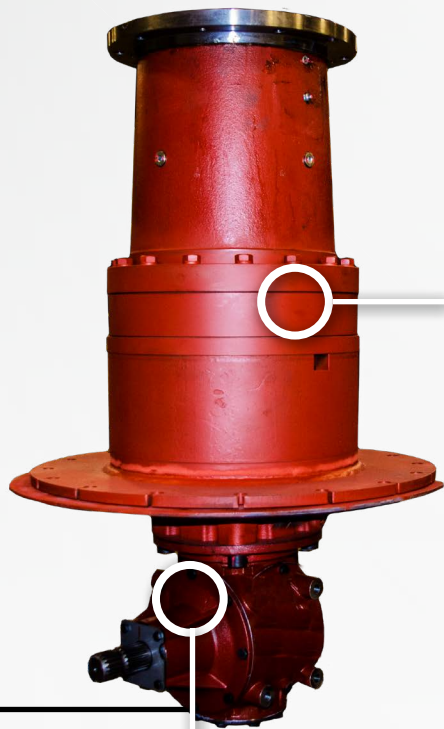

90 DEGREE GEARBOX

TWO-STAGE HD PLANETARY DRIVE

The two stage planetary drive has higher torque ratings than other manufacturers' single stage planetaries.

PATENTED CYLINDRICAL AUGER

Supreme's augers feature cylindrical flighting, giving the mix ultimate consistency and volcanic movement.



REPLACEABLE FORGE CUTTING BLADES

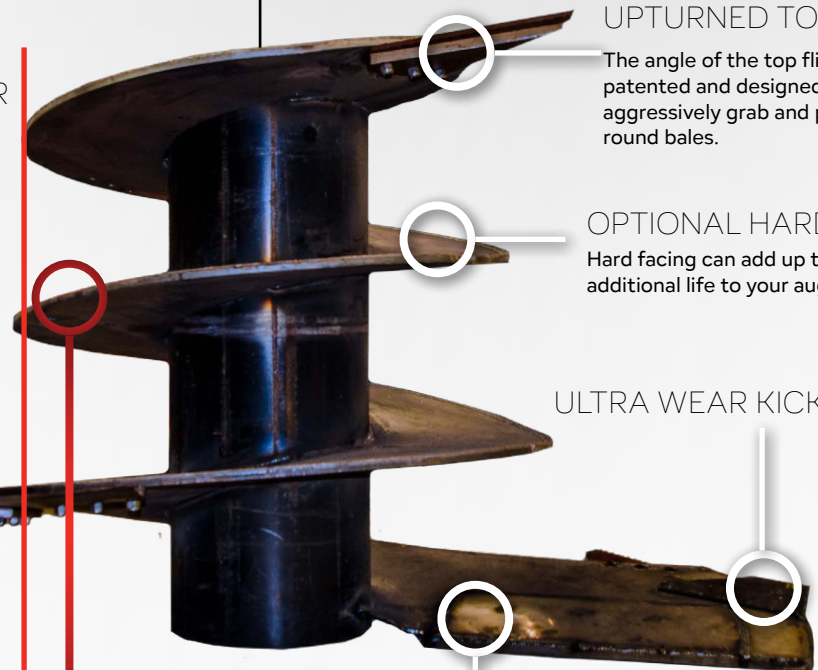

UPTURNED TOP KNIFE

The angle of the top flight is patented and designed to more aggressively grab and process round bales.

OPTIONAL HARD FACING

Hard facing can add up to 30% additional life to your augers.

ULTRA WEAR KICKER PLATE

AR200 FLIGHTING

SD, HD and XD auger flighting is made up of AR200 Steel, giving you the toughest and longest lasting augers on the market.

SS LEADING EDGE ON MOST MODELS

Standard Features on Supreme Pull-Type Mixers

- Patented Freestanding Vertical Cutting Auger(s)
- Manual Restrictor Plates
- Heavy-Duty, Two-Stage Planetary Drive(s)
- Replaceable Forage Cutting Blades
- Heavy-Duty Tubular Steel Frame
- M/S Floor - 5/8" / 16 mm on 300 and 400, 3/4" / 19 mm on 500 - 900T, 1" / 25 mm on 1000T and up
- 1/4" / 6 mm Walls (5/16" / 8 mm 1500TR, 1700TR & 1900TR)
- 5/8" / 16 mm Auger Flighting
- Side Door with Drop Chute (300 - 600)
- Front Center Door with Flat Conveyor (500T and up)
- Ultra Wear Kicker Plates
- Removable Hitch Jack (Heavy Duty on 500 and up)
- DG 500 Scale
- 12 Volt Battery
- SS Conveyor Top Pan
- Viewing Platform

300 PULL-TYPE

Empty Weight	5,700 lbs	2,585 kg
Max Payload at 5MPH	6,000 lbs	2,722 kg
Height	98 in	249 cm
Height with 10" Extension	108 in	274 cm
Overall Width	96 in	244 cm
Overall Length	170 in	432 cm
Min. Power Required	50 hp	37 kW
Capacity with Extension	275 ft ³	7.8 m ³
Capacity Struck Level	231 ft ³	6.5 m ³

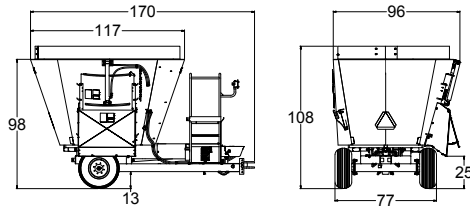

Standard Equipment

- (4) Replaceable Forage Cutting Blades
- Left or Right Hand Side Door w/ Drop Chute
- (2) 12.5L-15, 12 Ply Rated Hwy Tires
- Patented Freestanding Vertical Mixing Auger
- Heavy-Duty Planetary Drive
- 540 RPM PTO
- 3 pt Scale System

Discharge Ground Clearance

SIDE DOOR	21" Fixed	Fixed Chute
	34" / 86 cm	25" / 64 cm
SIDE DOOR	36" Fold	44" Fold
	41" / 104 cm	44" / 112 cm



400 PULL-TYPE

Empty Weight	6,400 lbs	2,903 kg
Max Payload at 5MPH	10,000 lbs	4,536 kg
Height	102 in	259 cm
Height with 10" Extension	112 in	284 cm
Overall Width	109 in	277 cm
Overall Length	177 in	450 cm
Min. Power Required	60 hp	45 kW
Capacity with Extension	378 ft ³	10.7 m ³
Capacity Struck Level	320 ft ³	9.1 m ³

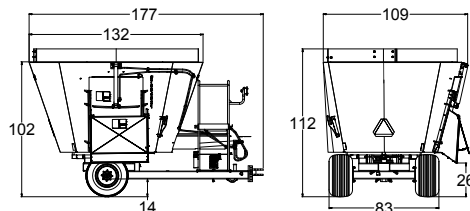

Standard Equipment

- (4) Replaceable Forage Cutting Blades
- Left or Right Hand Side Door w/ Drop Chute
- (2) 19x45x17 Flotation Implement Tires
- Patented Freestanding Vertical Mixing Auger
- Heavy-Duty Planetary Drive
- 540 RPM PTO
- 3 pt Scale System

Discharge Ground Clearance

SIDE DOOR	21" Fixed	Fixed Chute
	35" / 89 cm	26" / 66 cm
SIDE DOOR	36" Fold	44" Fold
	42" / 107 cm	45" / 114 cm





Standard Equipment

- (5) Replaceable Forage Cutting Blades
- Left or Right Hand Side Door w/ Drop Chute
- Solid Truck Axle w/ (4) 235x75x17.5 Tires
- Patented Freestanding Vertical Mixing Auger
- Heavy-Duty Planetary Drive
- 540 or 1,000 RPM PTO
- 3 pt Scale System

Discharge Ground Clearance

SIDE DOOR	F. Chute	21" Fixed	36" Fold
		27" / 69 cm	36" / 91 cm 42" / 107 cm
	44" Fold	72" Fold	96" Fold
	46" / 117 cm	57" / 145 cm	68" / 173 cm
FRONT DOOR	Flat	Dogleg	Ext. Dogleg
		27" / 69 cm	40" / 102 cm 51" / 130 cm
	42" Fold	54" Fold	
	44" / 112 cm	49" / 124 cm	

500 PULL-TYPE

Empty Weight	9,000 lbs	4,082 kg
Max Payload at 5MPH	14,000 lbs	6,350 kg
Height	105 in	267 cm
Height with 10" Extension	115 in	292 cm
Overall Width	103 in	262 cm
Overall Length	221 in	561 cm
Min. Power Required	100 hp	75 kW
Capacity with Extension	459 ft³	13.0 m³
Capacity Struck Level	394 ft³	11.2 m³

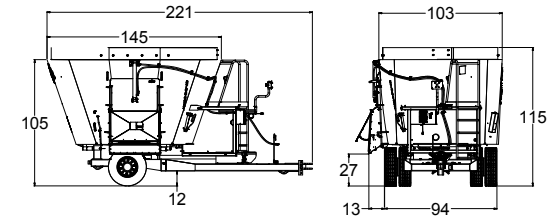

Standard Equipment

- (5) Replaceable Forage Cutting Blades
- Left or Right Hand Side Door w/ Drop Chute
- Solid Truck Axle w/ (4) 235x75x17.5 Tires
- Patented Freestanding Vertical Mixing Auger
- Heavy-Duty Planetary Drive
- 540 or 1,000 RPM PTO
- 3 pt Scale System

Discharge Ground Clearance

SIDE DOOR	F. Chute	21" Fixed	36" Fold
		26" / 66 cm	36" / 91 cm 42" / 107 cm
	44" Fold	72" Fold	96" Fold
	46" / 117 cm	57" / 145 cm	68" / 173 cm
FRONT DOOR	Flat	Dogleg	Ext. Dogleg
		27" / 69 cm	40" / 102 cm 51" / 130 cm
	42" Fold	54" Fold	
	44" / 112 cm	49" / 124 cm	

600 PULL-TYPE

Empty Weight	9,700 lbs	4,400 kg
Max Payload at 5MPH	14,000 lbs	6,350 kg
Height	115 in	292 cm
Height with 10" Extension	125 in	318 cm
Overall Width	103 in	262 cm
Overall Length	224 in	569 cm
Min. Power Required	100 hp	75 kW
Capacity with Extension	534 ft³	15.1 m³
Capacity Struck Level	465 ft³	13.2 m³

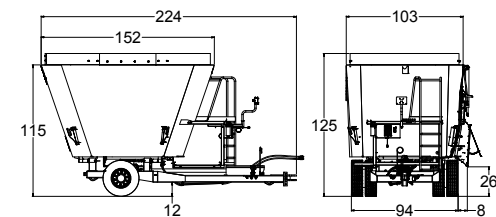

500T PULL-TYPE

Empty Weight	10,800 lbs	4,899 kg
Max Payload at 5MPH	14,000 lbs	6,350 kg
Height	100 in	254 cm
Height with 10" Extension	110 in	279 cm
Overall Width	99 in	251 cm
Overall Length	241 in	612 cm
Min. Power Required	80 hp	60 kW
Capacity with Extension	555 ft ³	15.7 m ³
Capacity Struck Level	479 ft ³	13.6 m ³

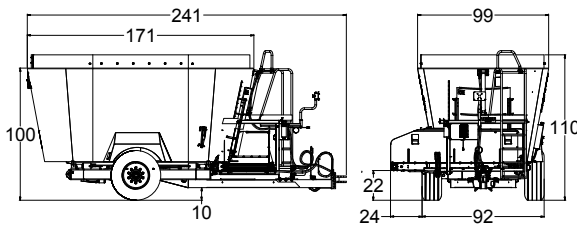

Standard Equipment

- Front Center Door With 8' Flat Conveyor
- (2) 435/50R19.5 Tires
- (8) Replaceable Knives
- (2) Patented Freestanding Vertical Mixing Augers
- (2) Heavy-Duty Planetary Drives
- 540 or 1,000 RPM PTO
- 4 pt Scale System

Discharge Ground Clearance

FRONT DOOR	Flat	Dogleg
	22" / 56 cm	35" / 89 cm
	Ext. Dogleg	42" Fold
	46" / 117 cm	39" / 99 cm
	54" Fold	
	44" / 112 cm	



600T PULL-TYPE

Empty Weight	11,700 lbs	5,307 kg
Max Payload at 5MPH	14,000 lbs	6,350 kg
Height	107 in	272 cm
Height with 10" Extension	117 in	297 cm
Overall Width	102 in	259 cm
Overall Length	254 in	645 cm
Min. Power Required	100 hp	75 kW
Capacity with Extension	635 ft ³	18.0 m ³
Capacity Struck Level	543 ft ³	15.4 m ³

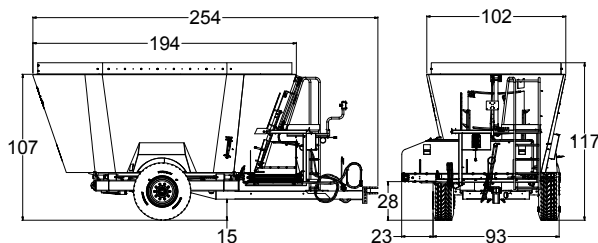

Standard Equipment

- Front Center Door With 8' Flat Conveyor
- (2) 385x65-22.5 Tires
- (10) Replaceable Knives
- (2) Patented Freestanding Vertical Mixing Augers
- (2) Heavy-Duty Planetary Drives
- 540 or 1,000 RPM PTO
- 4 pt Scale System

Discharge Ground Clearance

FRONT DOOR	Flat	Dogleg
	28" / 71 cm	41" / 104 cm
	Ext. Dogleg	42" Fold
	52" / 132 cm	43" / 109 cm
	54" Fold	
	48" / 122 cm	



700T PULL-TYPE



Standard Equipment

- Front Center Door With 8' Flat Conveyor
- (2) 385x65-22.5 Tires
- (10) Replaceable Knives
- (2) Patented Freestanding Vertical Mixing Augers
- (2) Heavy-Duty Planetary Drives
- 540 or 1,000 RPM PTO
- 4 pt Scale System

Discharge Ground Clearance

FRONT DOOR	Flat	Dogleg
	28" / 71 cm	41" / 104 cm
FRONT DOOR	Ext. Dogleg	42" Fold
	52" / 132 cm	43" / 109 cm
FRONT DOOR	54" Fold	
	48" / 122 cm	

Empty Weight	11,700 lbs	5,307 kg
Max Payload at 5MPH	14,000 lbs	6,350 kg
Height	116 in	295 cm
Height with 10" Extension	126 in	320 cm
Overall Width	103 in	262 cm
Overall Length	242 in	615 cm
Min. Power Required	100 hp	75 kW
Capacity with Extension	649 ft³	18.4 m³
Capacity Struck Level	565 ft³	16.0 m³

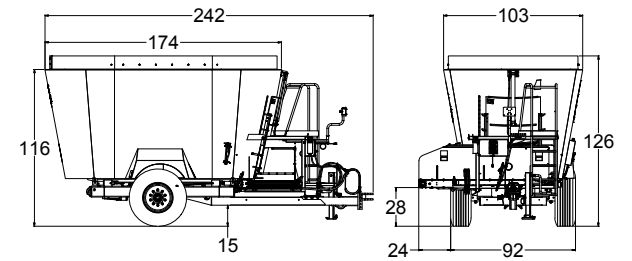

Standard Equipment

- Front Center Door With 8' Flat Conveyor
- (2) 385x65-22.5 Tires
- (10) Replaceable Knives
- (2) Patented Freestanding Vertical Mixing Augers
- (2) Heavy-Duty Planetary Drives
- 1,000 RPM PTO
- 4 pt Scale System

Discharge Ground Clearance

FRONT DOOR	Flat	Dogleg
	28" / 71 cm	42" / 107 cm
FRONT DOOR	Ext. Dogleg	42" Fold
	53" / 135 cm	44" / 112 cm
FRONT DOOR	54" Fold	
	49" / 125 cm	

800T PULL-TYPE

Empty Weight	14,515 lbs	6,584 kg
Max Payload at 5MPH	18,000 lbs	8,165 kg
Height	107 in	272 cm
Height with 10" Extension	117 in	297 cm
Overall Width	116 in	295 cm
Overall Length	271 in	688 cm
Min. Power Required	115 hp	86 kW
Capacity with Extension	746 ft³	21.1 m³
Capacity Struck Level	642 ft³	18.2 m³

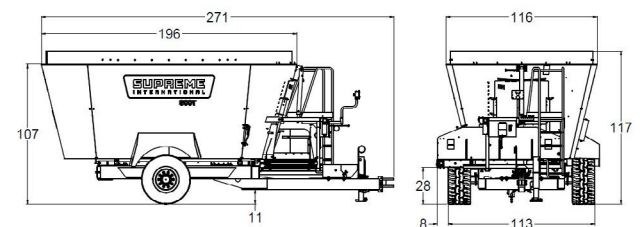

900T PULL-TYPE

Empty Weight	16,259 lbs	7,375 kg
Max Payload at 5MPH	24,000 lbs	10,886 kg
Height	117 in	297 cm
Height with 10" Extension	127 in	323 cm
Overall Width	123 in	312 cm
Overall Length	273 in	693 cm
Min. Power Required	130 hp	97 kW
Capacity with Extension	841 ft ³	23.8 m ³
Capacity Struck Level	731 ft ³	20.7 m ³

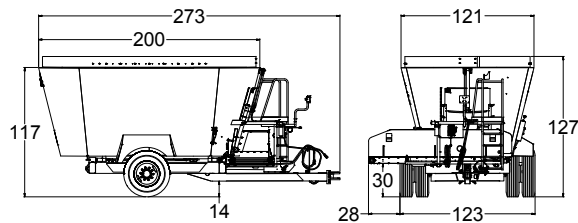

Standard Equipment

- Front Center Door With 10' Flat Conveyor
- (4) 11R/22.5 16 Ply Truck Tires
- (10) Replaceable Knives
- SS Auger Outer Edge
- (2) Patented Freestanding Vertical Mixing Augers
- (2) Heavy-Duty Planetary Drives
- 540 or 1,000 RPM PTO
- 4 pt Scale System

Discharge Ground Clearance

FRONT DOOR	Flat	Dogleg
	30" / 76 cm	44" / 112 cm
	Ext. Dogleg	
	55" / 140 cm	42" Fold 53" / 135 cm
	54" Fold	
	60" / 152 cm	



900T PULL-TYPE

TANDEM AXLE

Empty Weight	18,524 lbs	8,402 kg
Max Payload at 5MPH	24,000 lbs	10,886 kg
Height	122 in	310 cm
Height with 10" Extension	132 in	335 cm
Overall Width	121 in	307 cm
Overall Length	273 in	693 cm
Min. Power Required	130 hp	97 kW
Capacity with Extension	841 ft ³	23.8 m ³
Capacity Struck Level	731 ft ³	20.7 m ³

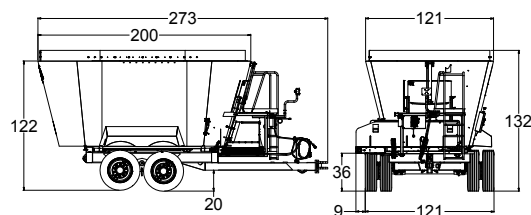

Standard Equipment

- Front Center Door With 10' Flat Conveyor
- (8) 275/70R 22.5 Tires w/ Walking Beam
- (10) Replaceable Knives
- SS Auger Outer Edge
- (2) Patented Freestanding Vertical Mixing Augers
- (2) Heavy-Duty Planetary Drives
- 540 or 1,000 RPM PTO
- 4 pt Scale System

Discharge Ground Clearance

FRONT DOOR	Flat	Dogleg
	36" / 91 cm	49" / 124 cm
	Ext. Dogleg	
	60" / 152 cm	42" Fold 58" / 147 cm
	54" Fold	
	65" / 165 cm	





Standard Equipment

- Front Center Door With 10' Flat Conveyor
- (8) 275/70R 22.5 Tires w/ Walking Beam
- (10) Replaceable Knives
- SS Auger Outer Edge
- (2) Patented Freestanding Vertical Mixing Augers
- (2) Heavy-Duty Planetary Drives
- 540 or 1,000 RPM PTO
- 4 pt Scale System

Discharge Ground Clearance

FRONT DOOR	Flat	Dogleg
	37" / 94 cm	50" / 127 cm
	Ext. Dogleg	42" Fold
	62" / 157 cm	60" / 152 cm
	54" Fold	
	67" / 170 cm	

1000T PULL-TYPE

TANDEM AXLE

Empty Weight	22,636 lbs	10,268 kg
Max Payload at 5MPH	40,000 lbs	18,144 kg
Height	114 in	290 cm
Height with 10" Extension	124 in	315 cm
Overall Width	121 in	307 cm
Overall Length	317 in	805 cm
Min. Power Required	170 hp	127 kW
Capacity with Extension	897 ft ³	25.4 m ³
Capacity Struck Level	779 ft ³	22.1 m ³

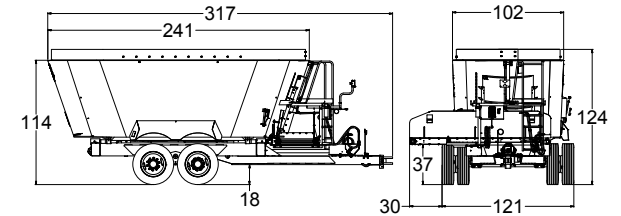

Standard Equipment

- Front Center Door With 10' Flat Conveyor
- (8) 275/70R 22.5 Tires w/ Walking Beam
- (10) Replaceable Knives
- SS Auger Outer Edge
- (2) Patented Freestanding Vertical Mixing Augers
- (2) Heavy-Duty Planetary Drives
- 540 or 1,000 RPM PTO
- 4 pt Scale System

Discharge Ground Clearance

SIDE DOOR	Fixed Chute		
	28" / 71 cm		
FRONT DOOR	Flat	Dogleg	Ext. Dogleg
	37" / 94 cm	50" / 127 cm	62" / 157 cm
	42" Fold	54" Fold	
	60" / 152 cm	67" / 170 cm	

1200T PULL-TYPE

TANDEM AXLE

Empty Weight	23,049 lbs	10,454 kg
Max Payload at 5MPH	40,000 lbs	18,144 kg
Height	121 in	307 cm
Height with 10" Extension	131 in	333 cm
Overall Width	121 in	307 cm
Overall Length	319 in	810 cm
Min. Power Required	180 hp	134 kW
Capacity with Extension	1,075 ft ³	30.4 m ³
Capacity Struck Level	935 ft ³	26.5 m ³

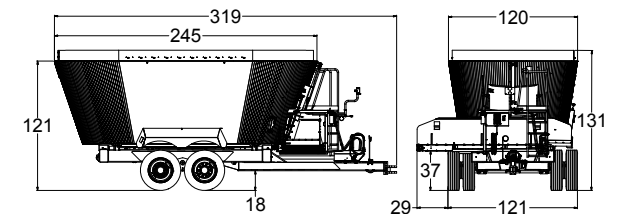

1400T PULL-TYPE

TANDEM AXLE

Empty Weight	27,316 lbs	12,390 kg
Max Payload at 5MPH	40,000 lbs	18,144 kg
Height	130 in	330 cm
Height with 10" Extension	140 in	356 cm
Overall Width	121 in	307 cm
Overall Length	328 in	833 cm
Min. Power Required	230 hp	172 kW
Capacity with Extension	1,305 ft ³	37.0 m ³
Capacity Struck Level	1,152 ft ³	32.6 m ³

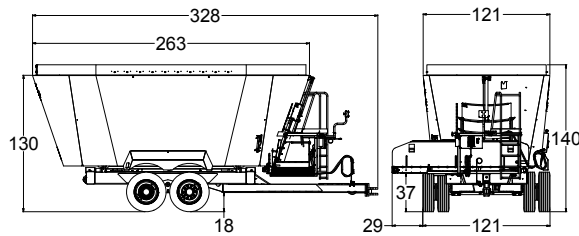

Standard Equipment

- Front Center Door With 10' Flat Conveyor
- (8) 275/70R 22.5 Tires w/ Walking Beam
- (10) Replaceable Knives
- SS Auger Outer Edge
- (2) Patented Freestanding Vertical Mixing Augers
- (2) Heavy-Duty Planetary Drives
- 1,000 RPM PTO
- 4 pt Scale System

Discharge Ground Clearance

Fixed Chute
28" / 71 cm

Flat 37" / 94 cm	Dogleg 50" / 127 cm	Ext. Dogleg 62" / 157 cm
---------------------	------------------------	-----------------------------

42" Fold 60" / 152 cm	54" Fold 67" / 170 cm
--------------------------	--------------------------



FRONT DOOR SIDE DOOR

1500TR PULL TYPE

TANDEM AXLE

Empty Weight	32,421 lbs	14,706 kg
Max Payload at 5MPH	50,000 lbs	22,680 kg
Height	131 in	333 cm
Height with 10" Extension	141 in	358 cm
Overall Width	121 in	307 cm
Overall Length	356 in	904 cm
Min. Power Required	200 hp	149 kW
Capacity with Extension	1,356 ft ³	38.4 m ³
Capacity Struck Level	1,192 ft ³	33.8 m ³

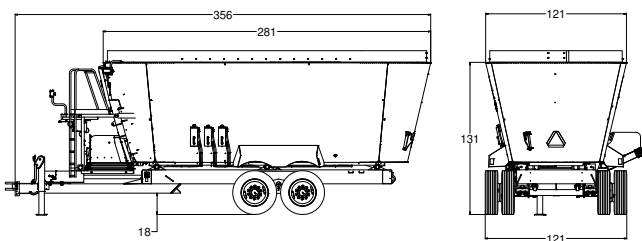

Standard Equipment

- Front Center Door With 10' Flat Conveyor
- (3) Patented Freestanding Vertical Cutting Augers
- (3) 2 Stage HD Planetaries
- (8) 275/70R 22.5 Tires w/ Walking Beam
- (15) Replaceable Knives
- SS Auger Outer Edge
- 1" / 25 mm 44W Floor
- 5/8" / 16 mm Auger Flighting
- 5/16" / 8 mm AR200 Walls
- 1,000 RPM PTO
- 6 pt Scale System

Discharge Ground Clearance

Fixed Chute
29" / 74 cm

Flat 38" / 97 cm	Dogleg 52" / 132 cm	Ext. Dogleg 63" / 160 cm
---------------------	------------------------	-----------------------------

42" Fold 61" / 155 cm	54" Fold 68" / 173 cm
--------------------------	--------------------------



FRONT DOOR SIDE DOOR

1700TR PULL-TYPE TANDEM AXLE



Standard Equipment

- Front Center Door With 10' Flat Conveyor
- (3) Patented Freestanding Vertical Cutting Augers
- (3) two-stage HD Planetaries
- (8) 275/70R 22.5 Tires w/ Walking Beam
- (15) Replaceable Knives
- SS Auger Outer Edge
- 1" / 25 mm 44W Floor
- 5/16" / 8 mm AR200 Walls
- 1,000 RPM PTO
- 6 pt Scale System

Discharge Ground Clearance

Fixed Chute
29" / 74 cm

FRONT DOOR	Flat	Dogleg	Ext. Dogleg
	38" / 97 cm	52" / 132 cm	63" / 160 cm
SIDE DOOR	42" Fold	54" Fold	
	61" / 155 cm	68" / 173 cm	

Empty Weight	33,837 lbs	15,348 kg
Max Payload at 5MPH	50,000 lbs	22,680 kg
Height	143 in	363 cm
Height with 10" Extension	153 in	389 cm
Overall Width	126 in	320 cm
Overall Length	358 in	909 cm
Min. Power Required	200 hp	149 kW
Capacity with Extension	1,566 ft³	44.3 m³
Capacity Struck Level	1,392 ft³	39.4 m³

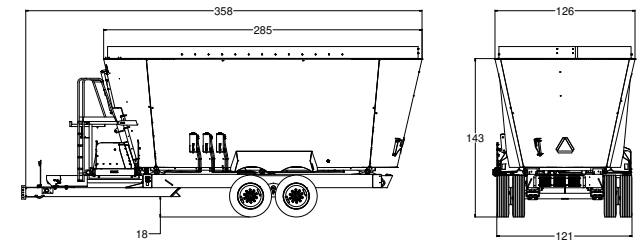

1900TR PULL-TYPE

TANDEM AXLE

Max Payload at 5MPH	60,000 lbs	27,216 kg
Height	146 in	371 cm
Height with 10" Extension	156 in	396 cm
Overall Width	130 in	330 cm
Overall Length	400 in	1,016 cm
Min. Power Required	250 hp	186 kW
Capacity with Extension	1,674 ft ³	47.4 m ³
Capacity Struck Level	1,873 ft ³	53.0 m ³

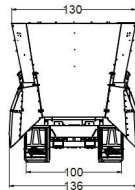
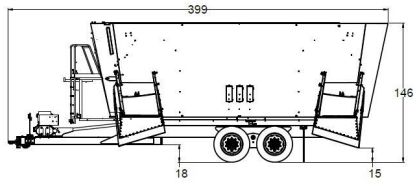

Standard Equipment

- Front Center Door With 10' Flat Conveyor
- (3) Patented Freestanding Vertical Cutting Augers
- (3) two-stage HD Planetaries
- (8) 275/70R 22.5 Tires w/ Walking Beam
- (12) 11R22.5 16 Ply Truck Tires
- (15) Replaceable Knives
- SS Auger Outer Edge
- 1" / 25 mm 44W Floor
- 5/16" / 8 mm AR200 Walls
- 1,000 RPM PTO
- 6 pt Scale System
- Two-Speed Autoshift Transmission

Discharge Ground Clearance

Fixed Chute
15" / 38 cm

Flat	Dogleg	Ext. Dogleg
37" / 94 cm	50" / 127 cm	62" / 157 cm
42" Fold	54" Fold	
60" / 152 cm	67" / 170 cm	

FRONT DOOR SIDE DOOR





1900TR PULL-TYPE

TRIDEM STEERABLE
BRAKING AXLE

Standard Equipment

- Front Center Door With 10' Flat Conveyor
- (3) Patented Freestanding Vertical Cutting Augers
- (3) two-stage HD Planetaries
- Tridem Steerable Braking ADR Axles w/ Greasable ADR Hubs
- (12) 11R22.5 16 Ply Truck Tires
- (15) Replaceable Knives
- SS Auger Outer Edge
- 1" / 25 mm 44W Floor
- 5/16" / 8 mm AR200 Walls
- 1,000 RPM PTO
- 6 pt Scale System
- Two-Speed Autoshift Transmission

Max Payload at 5MPH	60,000 lbs	27,216 kg
Height	150 in	381 cm
Height with 10" Extension	160 in	406 cm
Overall Width	130 in	330 cm
Overall Length	399 in	1,013 cm
Min. Power Required	250 hp	186 kW
Capacity with Extension	1,873 ft ³	53.0 m ³
Capacity Struck Level	1,674 ft ³	47.4 m ³

Discharge Ground Clearance

FRONT DOOR
SIDE DOOR

Fixed Chute
35" / 89 cm

Flat	Dogleg	Ext. Dogleg
41" / 104 cm	55" / 140 cm	66" / 168 cm

42" Fold	54" Fold
64" / 163 cm	71" / 180 cm

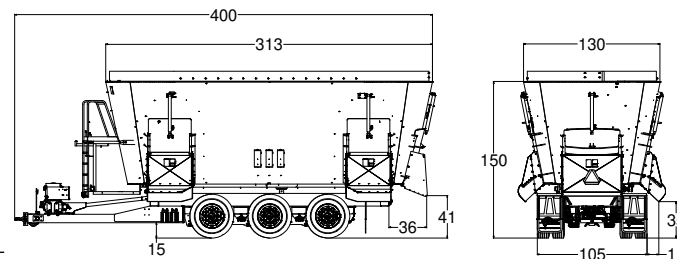



TRUCK MOUNT MIXERS





AVAILABLE IN MECHANICAL AND GEN 3

Standard Features on Supreme Truck Mount Mixers

- Two Patented Freestanding Vertical Cutting Augers
- Manual Restrictor Plates
- Replaceable Forage Cutting Blades
- Ultra Wear Kicker Plates
- Front Center Discharge Door
- Viewing Platform
- SS Conveyor Top Pan
- 8' Flat Variable Speed Hydraulic Driven Chain Discharge Conveyor with Hydraulic Extender
- 4 pt Scale System
- Tub Mounted Remote Display
- Cab Display
- Heavy-Duty Tubular Steel Bolsters
- 3/4" M/S Floor
- 1/4" AR200 Walls
- 5/8" AR200 Auger Flighting

MECHANICAL DRIVE

Supreme Mechanical Truck Mount mixers are twin auger models ranging from 480 - 649 ft³. These mixers use a similar drive system to our mechanical pull-types, and include features like HD two-stage planetaries, AR200 walls, and our patented tub and auger design.



500T TRUCK MOUNT MECHANICAL DRIVE

Empty Weight ^{***}	11,500 lbs	5,216 kg
Maximum Payload	10,000 lbs	4,535 kg
Height*	82 in	208 cm
Height with 10" Extension	92 in	234 cm
Overall Width**	99 in	251 cm
Overall Length**	211 in	536 cm
Min. Power Required	210 hp	157 kW
Capacity with Extension	555 ft ³	15.7 m ³
Capacity Struck Level	479 ft ³	13.6 m ³

Standard Equipment

- (2) HD two-stage Planetaries
- (8) Replaceable Knives

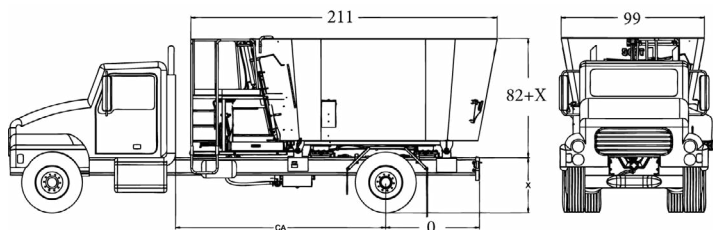

*Height of truck frame to top of tub. Add to truck frame height for overall height.
 **Overall width and length dependent on style of truck, conveyor/discharge options ordered. Standard unit may not be as shown.
 ***Empty weight excludes truck chassis



600T TRUCK MOUNT

MECHANICAL DRIVE

Standard Equipment

- (2) HD two-stage Planetaries
- (10) Replaceable Knives

Empty Weight***	12,280 lbs	5,570 kg
Maximum Payload	10,000 lbs	4,535 kg
Height*	84 in	213 cm
Height with 10" Extension	94 in	239 cm
Overall Width**	102 in	259 cm
Overall Length**	223 in	566 cm
Min. Power Required	260 hp	194 kW
Capacity with Extension	635 ft ³	18.0 m ³
Capacity Struck Level	543 ft ³	15.4 m ³

*Height of truck frame to top of tub. Add to truck frame height for overall height.
 **Overall width and length dependent on style of truck, conveyor/discharge options ordered. Standard unit may not be as shown.
 ***Empty weight excludes truck chassis

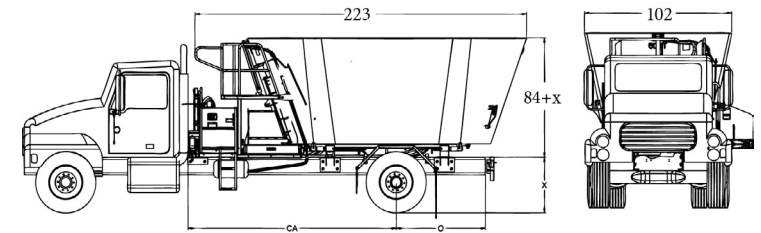

700T TRUCK MOUNT

MECHANICAL DRIVE

Standard Equipment

- (2) HD two-stage Planetaries
- (10) Replaceable Knives

Empty Weight***	12,385 lbs	5,618 kg
Maximum Payload	10,000 lbs	4,535 kg
Height*	92 in	234 cm
Height with 10" Extension	102 in	259 cm
Overall Width**	102 in	259 cm
Overall Length**	213 in	541 cm
Min. Power Required	260 hp	194 kW
Capacity with Extension	649 ft ³	18.4 m ³
Capacity Struck Level	565 ft ³	16.0 m ³

*Height of truck frame to top of tub. Add to truck frame height for overall height.
 **Overall width and length dependent on style of truck, conveyor/discharge options ordered. Standard unit may not be as shown.
 ***Empty weight excludes truck chassis

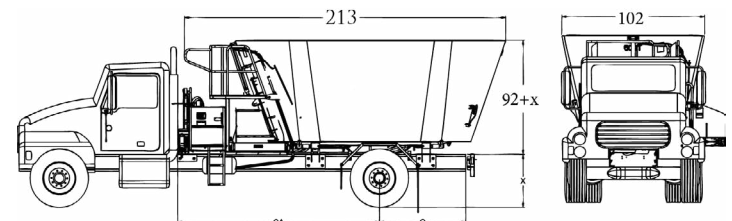

GEN 3 DRIVE

Our **Supreme Gen 3 Truck Mount**. Powered by our innovative drive system.

Groundbreaking Features Include:

- An Advanced Automated Control System for Consistent Feed Processing and Accurate Delivery Every Time
- Low Torque Requirement Ensures Longer Component Life, Lower Fuel Consumption, Reduced Operating Costs
- Unparalleled Controls Provide Exceptional Operator Comfort, Reduced Fatigue and Increasing Productivity
- Protect Your Investment with Confidence Using Our Real-Time System Monitoring

With this innovative drive system, which features robust heavy-duty planetaries run hydrostatically, the operator has absolute automatic auger control in three modes: Loading, Mixing and Unloading.

- » **Loading mode** - the system is intelligently tailored to the way you load
- » **Mixing mode** - full control ensures consistent and efficient mixing
- » **Unloading mode** - provides accurate discharge - with the push of a button





Standard Equipment

- (2) Heavy-Duty Planetaries
- Planetary Cooling
- Reversing Fan
- (10) Replaceable Forage Cutting Blades
- Armrest-Mounted Ergonomic Joystick
- Digital Service Reminders
- 5.7" High Resolution LCD Display

900T TRUCK MOUNT

GEN 3 DRIVE

Empty Weight***	13,675 lbs	6,203 kg
Maximum Payload	24,000 lbs	10,886 kg
Height*	91 in	231 cm
Height with 10" Extension	101 in	257 cm
Overall Width	120 in	305 cm
Overall Length	253 in	643 cm
Min. Power Required	300 hp	224 kW
Capacity with Extension	841 ft ³	23.8 m ³
Capacity Struck Level	731 ft ³	20.7 m ³

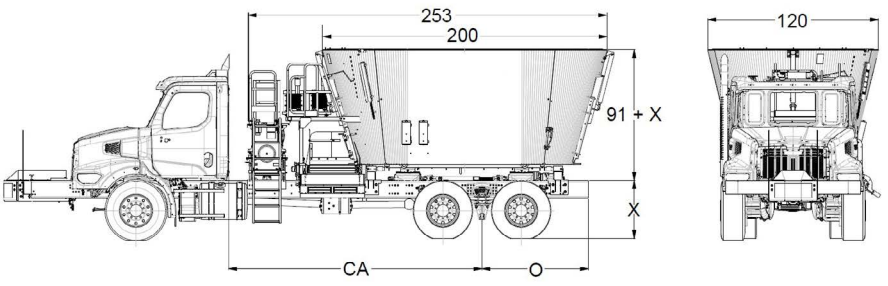

*Height of truck frame to top of tub. Add to truck frame height for overall height.
 **Overall width and length dependent on style of truck, conveyor / discharge options ordered. Standard unit may not be as shown.
 ***Empty weight excludes truck chassis



Standard Equipment

- (2) Heavy-Duty Planetaries
- Planetary Cooling
- Reversing Fan
- (10) Replaceable Forage Cutting Blades
- Armrest-Mounted Ergonomic Joystick
- Digital Service Reminders
- 1" / 25mm 44W Floor
- 5.7" High Resolution LCD Display

1050T TRUCK MOUNT

GEN 3 DRIVE

Empty Weight***	15,400 lbs	6,985 kg
Maximum Payload	40,000 lbs	18,144 kg
Height*	82 in	208 cm
Height with 10" Extension	92 in	234 cm
Overall Width	120 in	305 cm
Overall Length	271 in	688 cm
Min. Power Required	370 hp	276 kW
Capacity with Extension	958 ft ³	27.1 m ³
Capacity Struck Level	830 ft ³	23.5 m ³

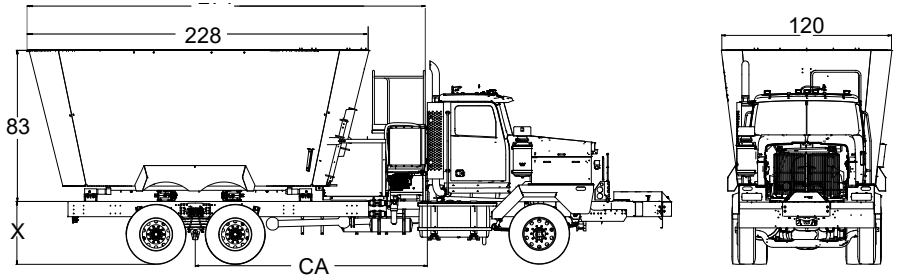

*Height of truck frame to top of tub. Add to truck frame height for overall height.
 **Overall width and length dependent on style of truck, conveyor / discharge options ordered. Standard unit may not be as shown.
 ***Empty weight excludes truck chassis

1250T TRUCK MOUNT

GEN 3 DRIVE

Empty Weight***	16,000 lbs	7,257 kg
Maximum Payload	40,000 lbs	18,144 kg
Height*	96 in	244 cm
Height with 10" Extension	106 in	269 cm
Overall Width	120 in	305 cm
Overall Length	277 in	704 cm
Min. Power Required	370 hp	276 kW
Capacity with Extension	1,131 ft ³	32.0 m ³
Capacity Struck Level	997 ft ³	28.2 m ³

Standard Equipment

- (2) Heavy-Duty Planetaries
- Planetary Cooling
- Reversing Fan
- (10) Replaceable Forage Cutting Blades
- Armrest-Mounted Ergonomic Joystick
- Digital Service Reminders
- 1" / 25mm 44W Floor
- 5.7" High Resolution LCD Display

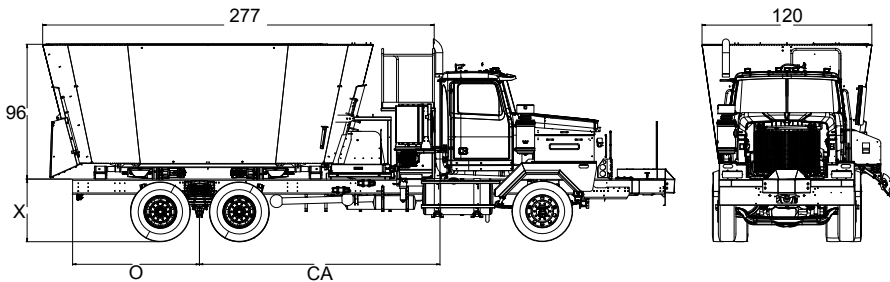

*Height of truck frame to top of tub. Add to truck frame height for overall height.
 **Overall width and length dependent on style of truck, conveyor / discharge options ordered. Standard unit may not be as shown.
 ***Empty weight excludes truck chassis

1450T TRUCK MOUNT

GEN 3 DRIVE

Empty Weight***	17,600 lbs	7,983 kg
Maximum Payload	40,000 lbs	18,144 kg
Height*	108 in	274 cm
Height with 10" Extension	118 in	300 cm
Overall Width	120 in	305 cm
Overall Length	282 in	716 cm
Min. Power Required	400 hp	298 kW
Capacity with Extension	1,298 ft ³	36.8 m ³
Capacity Struck Level	1,161 ft ³	32.9 m ³

Standard Equipment

- (2) Heavy-Duty Planetaries
- Planetary Cooling
- Reversing Fan
- (10) Replaceable Forage Cutting Blades
- Armrest-Mounted Ergonomic Joystick
- Digital Service Reminders
- 5.7" High Resolution LCD Display
- 1" / 25mm 44W Floor
- 5/16" / 8 mm AR200 Walls

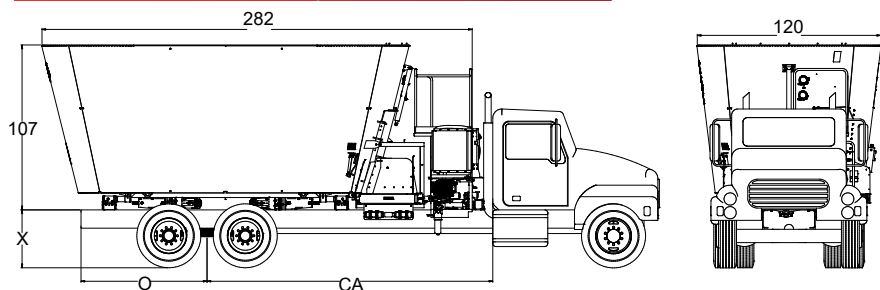

*Height of truck frame to top of tub. Add to truck frame height for overall height.
 **Overall width and length dependent on style of truck, conveyor / discharge options ordered. Standard unit may not be as shown.
 ***Empty weight excludes truck chassis



SUPREME
INTERNATIONAL

1050T XD

TRUCK REQUIREMENTS FOR SUPREME MECHANICAL TRUCK MOUNTED FEED MIXERS 500T - 700T

- C-A - must have no exhaust interference
- measure C-A from exhaust stack(s) if exhaust is behind cab
 - minimum of 20" open-inside frame behind cab for gear box

RECOMMENDATIONS: Less than 3 mph ground speed (the slower the better if 3 mph is not possible) in low gear at constant 1600RPM (Automatic or Standard) direct access to crankshaft, hour-meter, heavy single frame or double frame, and a 135 amp alternator. High idle to be programmed for 1200-1400-1600RPM if possible. If only one or two high idle settings are possible then choose from these three values. Low idle to be programmed at 800RPM if possible.

TRANSMISSION PTO REQUIREMENTS: 80-100% engine rotation – 500TMTM minimum 300 ft/lbs torque, 600TMTM / 700TMTM requires Heavy Duty PTO with a minimum 450 ft/lbs "Hot shift"

FRAME REQUIREMENT:

Minimum 500,000 in/lbs working modulus
[10 5/8" x 5/16" straight channel frame rail]

Not intended for highway use.



Minimum	MECHANICAL	
	500T MTM	600T/700T MTM
CAB TO AXLE (C-A) w/ platform and conveyor	138" / 351 cm	138" / 351 cm
CAB TO AXLE (C-A) side doors no platform, no conveyor	N/A	N/A
OVERHANG (O)	62" / 157 cm	62" / 157 cm
FRONT SUSPENSION AXLE	12,000 lbs 5,443 kg	12,000 lbs 5,443 kg
REAR SUSPENSION AXLE	23,000 lbs 10,433 kg	23,000 lbs 10,433 kg
DIESEL POWER	210 hp 157 kW	260 hp 194 kW
TRANSMISSION	ALLISON 653 & UP	ALLISON 3000 & UP

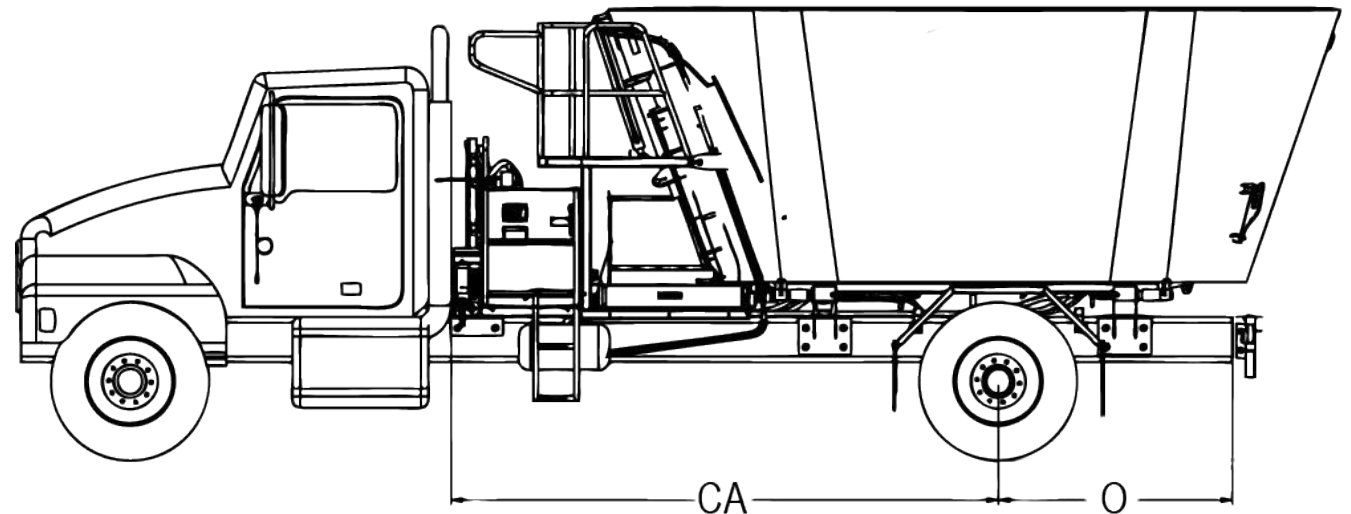

**TRUCK REQUIREMENTS
FOR SUPREME GEN3 TRUCK MOUNTED FEED MIXERS
900T, 1050T, 1250T and 1450T**

- Dash mounted transmission controls
- Drivers seat arm rests
- Single passenger seat
- Flat open floor between seats
- Clear passenger side frame rail

Cab to Axle

- Must have no exhaust interference
- Measure C-A from exhaust stack(s) if exhaust is behind cab

RECOMMENDATIONS: Less than 3 mph ground speed (the slower the better if 3 mph is not possible) in low gear at constant 1600RPM (Automatic or Standard) direct access to crankshaft, hour-meter, heavy single frame or double frame, and a 160 amp alternator. High idle to be programmed for 1200-1400-1600RPM if possible. If only one or two high idle settings are possible then choose from these three values. Low idle to be programmed at 800RPM if possible.

FEPTO: front engine PTO. Pumps mount ahead of cab.

REPTO: rear engine PTO. Pumps mount behind cab. Note that this is not a transmission **PTO**.

Not intended for highway use.



Minimum	GEN3					
	900T		1050T/1250T		1450T	
	FEPTO	REPTO	FEPTO	REPTO	FEPTO	REPTO
CAB TO AXLE (C-A) w/ platform and conveyor	168" / 427 cm	180" / 457 cm	185" / 470 cm	197" / 500 cm	185" / 470 cm	197" / 500 cm
CAB TO AXLE (C-A) side doors no platform, no conveyor	N/A		N/A		N/A	
OVERHANG (O)	70" / 178 cm		86" / 218 cm		90" / 229 cm	
FRONT SUSPENSION AXLE	12,000 lbs 5,443 kg		14,000 lbs 6,350 kg		18,000 lbs 8,165 kg	
REAR SUSPENSION AXLE	40,000 lbs 18,144 kg		40,000 lbs 18,144 kg		46,000 lbs 20,865 kg	
DIESEL POWER	300 hp 224 kW		370 hp 276 kW		400 hp 298 kW	
TRANSMISSION	AUTOMATIC		AUTOMATIC		AUTOMATIC	

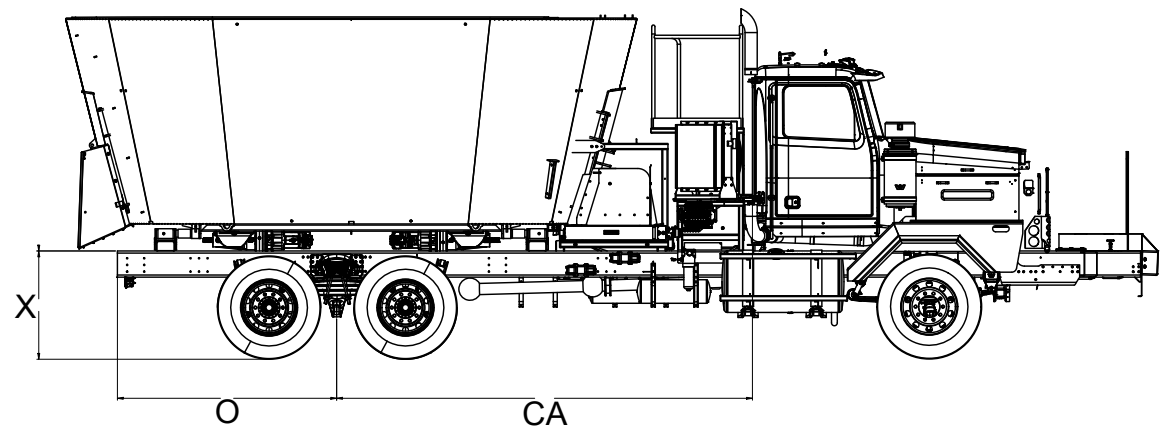



SUPREME
INTERNATIONAL
1400T SD

STATIONARY MIXERS

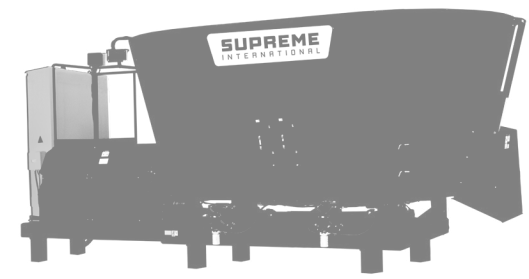



AVAILABLE IN
MECHANICAL
AND GEN 3

Standard Features on Supreme Stationary Mixers

- Two Patented Freestanding Vertical Cutting Augers
- Manual Restrictor Plates
- Replaceable Forage Cutting Blades
- Ultra Wear Kicker Plates
- Rear Discharge Door
- Viewing Platform
- 3 pt Scale System for Single Auger Models
- 4 pt Scale System for Twin Auger Models
- 6 pt Scale System for Triple Auger Models
- Tub Mounted Remote Display
- Heavy-Duty Tubular Steel Frame
- M/S Floor - 5/8" / 16 mm on 300 and 400, 3/4" / 19 mm on 500 - 900T, 1" / 25 mm on 1000T and up
- 1/4" AR200 Walls, 5/16" AR200 Walls on 1450 and Larger Models
- 5/8" AR200 Auger Flighting



MECHANICAL DRIVE

Mechanical drive stationaries are an energy efficient way to mix your feed and can be powered by electric or diesel power. Like our Pull-Type models they run with robust heavy-duty planetary drives. Available in most mixer model sizes.

All models are equipped with end door and fixed chute for ease unloading of mixed wet or dry commodities. Various pedestal heights are available to fit each operation's requirements.

300 STATIONARY

MECHANICAL DRIVE

Empty Weight	6,544 lbs	2,968 kg
Maximum Payload	6,000 lbs	2,722 kg
Height w/6" Pedestals	92 in	234 cm
Height with 10" Extension	102 in	259 cm
Overall Width	92 in	234 cm
Overall Length	200 in	508 cm
Min. Power Required	50 hp	37 kW
Capacity with Extension	275 ft ³	7.8 m ³
Capacity Struck Level	231 ft ³	6.5 m ³

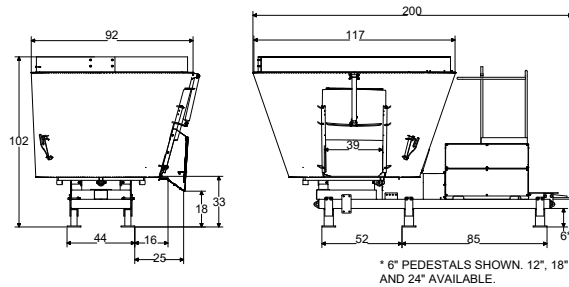

400 STATIONARY

MECHANICAL DRIVE

Empty Weight	7,394 lbs	3,354 kg
Maximum Payload	10,000 lbs	4,436 kg
Height w/6" Pedestals	95 in	241 cm
Height with 10" Extension	105 in	267 cm
Overall Width	105 in	267 cm
Overall Length	207 in	526 cm
Min. Power Required	50 hp	37 kW
Capacity with Extension	378 ft ³	10.7 m ³
Capacity Struck Level	320 ft ³	9.1 m ³

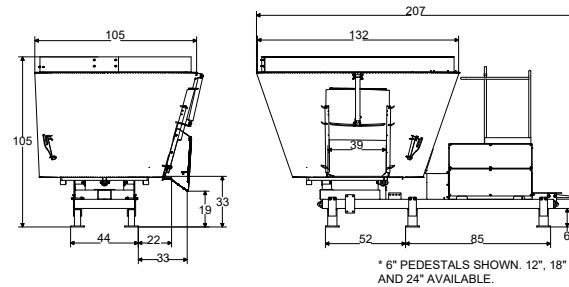

500 STATIONARY

MECHANICAL DRIVE

Empty Weight	9,767 lbs	4,430 kg
Maximum Payload	14,000 lbs	6,350 kg
Height w/6" Pedestals	101 in	257 cm
Height with 10" Extension	111 in	282 cm
Overall Width	103 in	262 cm
Overall Length	217 in	551 cm
Min. Power Required	75 hp	56 kW
Capacity with Extension	459 ft ³	13.0 m ³
Capacity Struck Level	394 ft ³	11.2 m ³

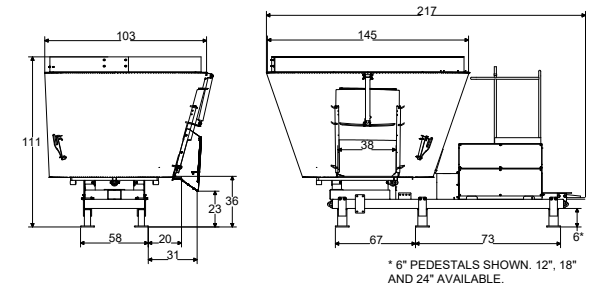

600 STATIONARY

MECHANICAL DRIVE

Empty Weight	10,108 lbs	4,585 kg
Maximum Payload	14,000 lbs	6,350 kg
Height w/6" Pedestals	112 in	284 cm
Height with 10" Extension	122 in	310 cm
Overall Width	103 in	262 cm
Overall Length	220 in	559 cm
Min. Power Required	75 hp	56 kW
Capacity with Extension	534 ft ³	15.1 m ³
Capacity Struck Level	465 ft ³	13.2 m ³

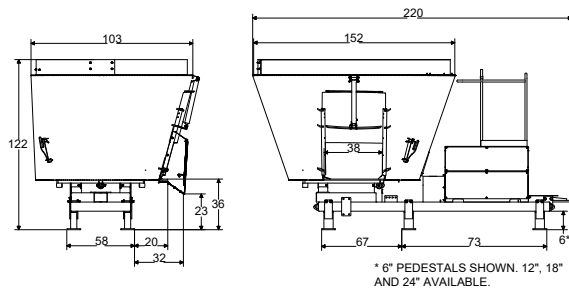

500T STATIONARY

MECHANICAL DRIVE

Empty Weight	11,838 lbs	5,370 kg
Maximum Payload	14,000 lbs	6,350 kg
Height w/6" Pedestals	97 in	246 cm
Height with 10" Extension	107 in	272 cm
Overall Width	99 in	251 cm
Overall Length	259 in	658 cm
Min. Power Required	75 hp	56 kW
Capacity with Extension	555 ft ³	15.7 m ³
Capacity Struck Level	479 ft ³	13.6 m ³

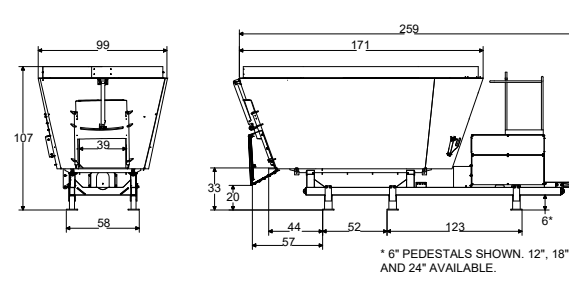

600T STATIONARY

MECHANICAL DRIVE

Empty Weight	12,689 lbs	5,756 kg
Maximum Payload	14,000 lbs	6,350 kg
Height w/6" Pedestals	97 in	246 cm
Height with 10" Extension	107 in	272 cm
Overall Width	103 in	262 cm
Overall Length	271 in	688 cm
Min. Power Required	100 hp	75 kW
Capacity with Extension	635 ft ³	18.0 m ³
Capacity Struck Level	543 ft ³	15.4 m ³

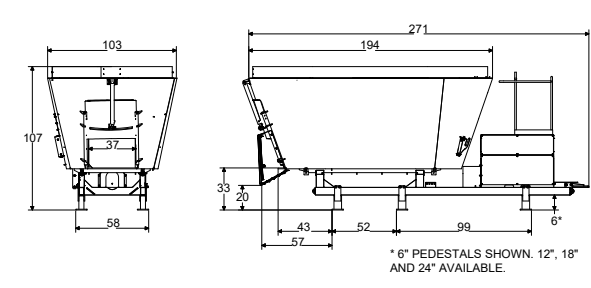

700T STATIONARY MECHANICAL DRIVE

Empty Weight	12,665 lbs	5,745 kg
Maximum Payload	14,000 lbs	6,350 kg
Height w/6" Pedestals	108 in	274 cm
Height with 10" Extension	118 in	300 cm
Overall Width	103 in	262 cm
Overall Length	261 in	663 cm
Min. Power Required	100 hp	75 kW
Capacity with Extension	649 ft ³	18.4 m ³
Capacity Struck Level	565 ft ³	16.0 m ³

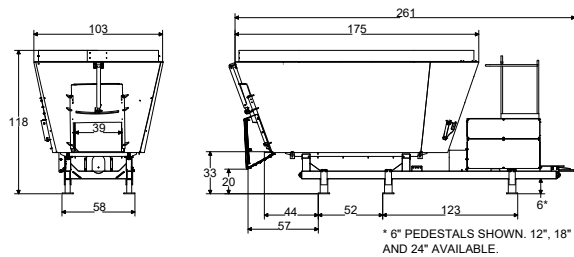

900T STATIONARY MECHANICAL DRIVE

Empty Weight	14,843 lbs	6,733 kg
Maximum Payload	24,000 lbs	10,886 kg
Height w/6" Pedestals	109 in	277 cm
Height with 10" Extension	119 in	302 cm
Overall Width	121 in	307 cm
Overall Length	284 in	721 cm
Min. Power Required	125 hp	93 kW
Capacity with Extension	841 ft ³	23.8 m ³
Capacity Struck Level	731 ft ³	20.7 m ³

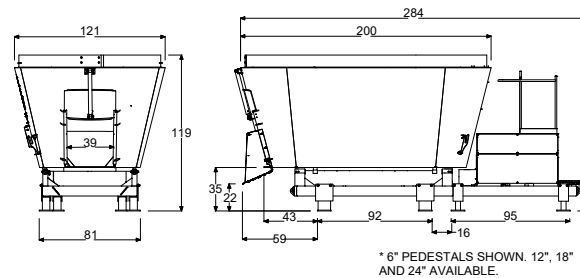

1200T STATIONARY MECHANICAL DRIVE

Empty Weight	21,323 lbs	9,672 kg
Maximum Payload	40,000 lbs	18,144 kg
Height w/6" Pedestals	114 in	290 cm
Height with 10" Extension	124 in	315 cm
Overall Width	103 in	262 cm
Overall Length	335 in	851 cm
Min. Power Required	200 hp	149 kW
Capacity with Extension	1,075 ft ³	30.4 m ³
Capacity Struck Level	935 ft ³	26.5 m ³

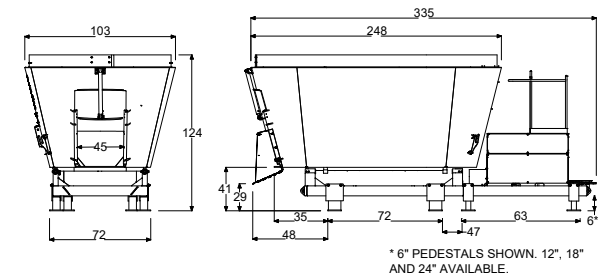

1400T STATIONARY MECHANICAL DRIVE

Empty Weight	22,748 lbs	10,318 kg
Maximum Payload	40,000 lbs	18,144 kg
Height	120 in	305 cm
Height with 10" Extension	130 in	330 cm
Overall Width	121 in	307 cm
Overall Length	342 in	869 cm
Min. Power Required	250 hp	186 kW
Capacity with Extension	1,305 ft ³	37.0 m ³
Capacity Struck Level	1,152 ft ³	32.6 m ³

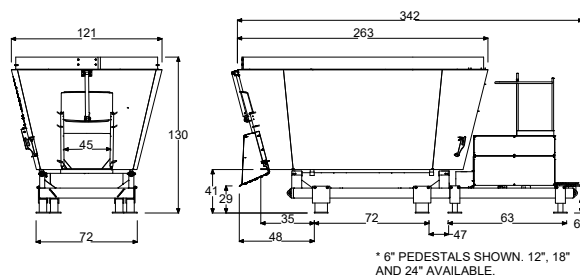

1500TR STATIONARY MECHANICAL DRIVE

Empty Weight	34,000 lbs	15,422 kg
Maximum Payload	50,000 lbs	22,680 kg
Height w/6" Pedestals	119 in	302 cm
Height with 10" Extension	129 in	328 cm
Overall Width	121 in	307 cm
Overall Length	382 in	970 cm
Min. Power Required	250 hp	186 kW
Capacity with Extension	1,356 ft ³	38.4 m ³
Capacity Struck Level	1,192 ft ³	33.8 m ³

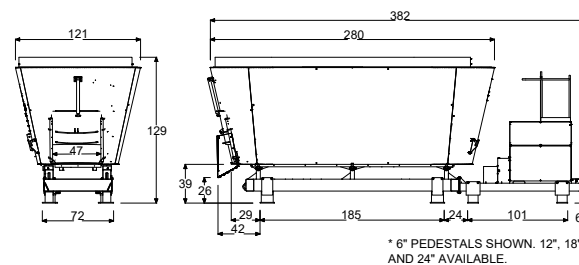

1700TR STATIONARY MECHANICAL DRIVE

Empty Weight	35,274 lbs	16,000 kg
Maximum Payload	50,000 lbs	22,680 kg
Height w/6" Pedestals	131 in	333 cm
Height with 10" Extension	141 in	358 cm
Overall Width	126 in	320 cm
Overall Length	382 in	970 cm
Min. Power Required	250 hp	186 kW
Capacity with Extension	1,566 ft ³	44.3 m ³
Capacity Struck Level	1,392 ft ³	39.4 m ³

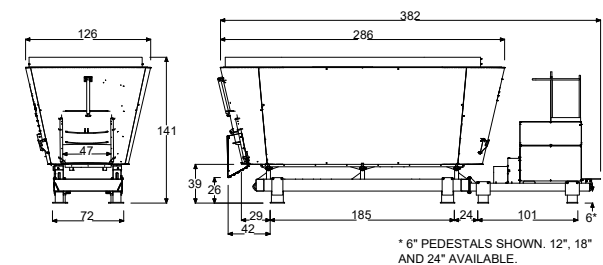



GEN 3 DRIVE

Our **Supreme Gen 3 Stationary**. Powered by our innovative drive system.

Groundbreaking Features Include:

- An Advanced Automated Control System for Consistent Feed Processing and Accurate Delivery Every Time
- Low Torque Requirement Ensures Longer Component Life, Lower Fuel Consumption, Reduced Operating Costs
- Protect Your Investment with Confidence Using Our Real-Time System Monitoring

With this innovative drive system, which features robust heavy-duty planetaries run hydrostatically, the operator has absolute automatic auger control in three modes: Loading, Mixing and Unloading.

- » **Loading mode** - the system is intelligently tailored to the way you load
- » **Mixing mode** - full control ensures consistent and efficient mixing
- » **Unloading mode** - provides accurate discharge - with the push of a button

1450TSH STATIONARY GEN 3 DRIVE

Maximum Payload	40,000 lbs	18,144 kg
Height**	130 in	330 cm
Height with 10" Extension**	140 in	356 cm
Overall Width	121 in	307 cm
Overall Length*	240 in	610 cm
Min. Power Required	250 hp	186 kW
Capacity with Extension	1,298 ft ³	36.8 m ³
Capacity Struck Level	1,161 ft ³	32.9 m ³

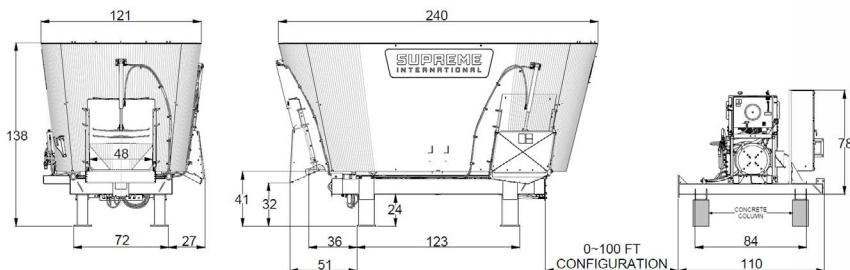

*Length of mixer tub only. Panel and motor skid can be placed separately from the mixer.
**Height with 24" pedestals.





REVOLUTIONARY FEED DELIVERY

SUPREME INTERNATIONAL® DELIVERY BOXES
TRUCK MOUNT AND PULL-TYPE



Standard Delivery Box Features

- 10 GA / 3.4 mm Stainless Steel Floor w/ 12" Lower Side Wall Liner
- Easy Access Back End
- "Auto Feed Floor Drive" Selectable System for Each Separate Ration
- 9' Flat Conveyor with Hydraulic Dropchute
- 4-Point Scale System
- 2 Viewing Windows
- Hydraulic Floor Chain Tensioner
- Fixed End
- Multi Function Joystick
- 5.7" High Resolution LCD Display
- SS Conveyor Top Pan
- Folding Ladder
- Clean-out Auger

AUTOMATION THAT CHANGES EVERYTHING

AUTO FEED FLOOR DRIVE

Unlike any other delivery system on the market, the Supreme International Delivery Box has a revolutionary **AUTO FEED FLOOR DRIVE** that simplifies feeding on a new level.

With a pressure sensing floor that automatically moves based on ration type, the operator no longer has to control the floor speed. This is one less step that the feeder has to accommodate for, and instead only has to focus on opening the discharge door and controlling conveyor speed.



END DUMP OPTION

The Supreme Delivery Box has the ability to open the rear door and reverse the floor chain, offering users the ability to deliver commodity batches quickly and effectively.

This end dump features a hydraulic tensioning system and simple hydraulic lift cylinders that make using the end door safe and easy.





24FOOT

TRUCK MOUNT DELIVERY BOX

Height*	92 in	234 cm
Height with 12" Extension	104 in	264 cm
Overall Width**	124 in	315 cm
Overall Length**	332 in	843 cm
Empty Weight***	16,000 lbs	7,257 kg
Min. Power Required	300 hp	224 kW
Maximum Payload	40,000 lbs	18,144 kg
Capacity with Extension	1,252 ft ³	35.5 m ³
Capacity Struck Level	1,108 ft ³	31.4 m ³

Standard Equipment

- 4-point Scale System with In-Cab Scale, Weight Repeater & Mirror Mount Display

Truck Requirements

- Allison 3500 RDS Transmission with PTO Provision
- Auxiliary Drop Box ATR or AT1202 3MPH-Low 65MPH- High
- Double Frame
- Corner Cab Exhaust Stack
- Passenger Side Inner Open Frame Behind Cab for Pump Drive to Transmission PTO
- Front Axle: 16,000# Rear Axle: 46,000#
- 204" Cab to Axle, 134" After Frame NO END DUMP
126" After Frame FOR END DUMP

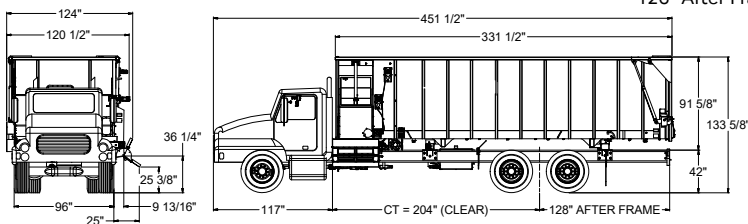

- * Height of truck frame to top of tub. Add to truck frame height for overall height.
- ** Overall width and length dependent on style of truck, conveyor/discharge options ordered.
- *** Empty weight excludes truck chassis



Standard Equipment

- Removable Heavy-Duty Hitch Jack
- Tandem Axle Walking Beam with (8) 11R22.5 Tires
- 1,000 RPM PTO
- 12V Battery
- Articulating Hitch

24FOOT

PULL-TYPE DELIVERY BOX

Maximum Payload	40,000 lbs	18,144 kg
Height*	131 in	333 cm
Height with 12" Extension	143 in	363 cm
Overall Width**	122 in	310 cm
Overall Length**	368 in	935 cm
Min. Power Required	180 hp	134 kW
Capacity with Extension	1,252 ft ³	35.5 m ³
Capacity Struck Level	1,108 ft ³	31.4 m ³

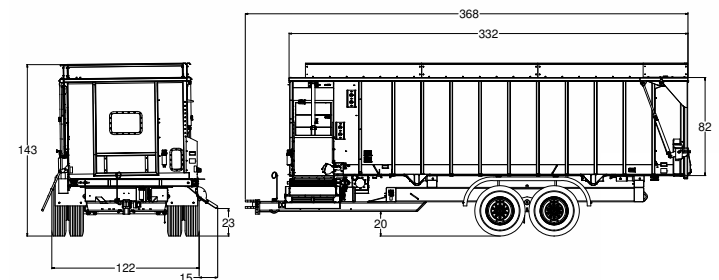

A FIT FOR EVERY OPERATION

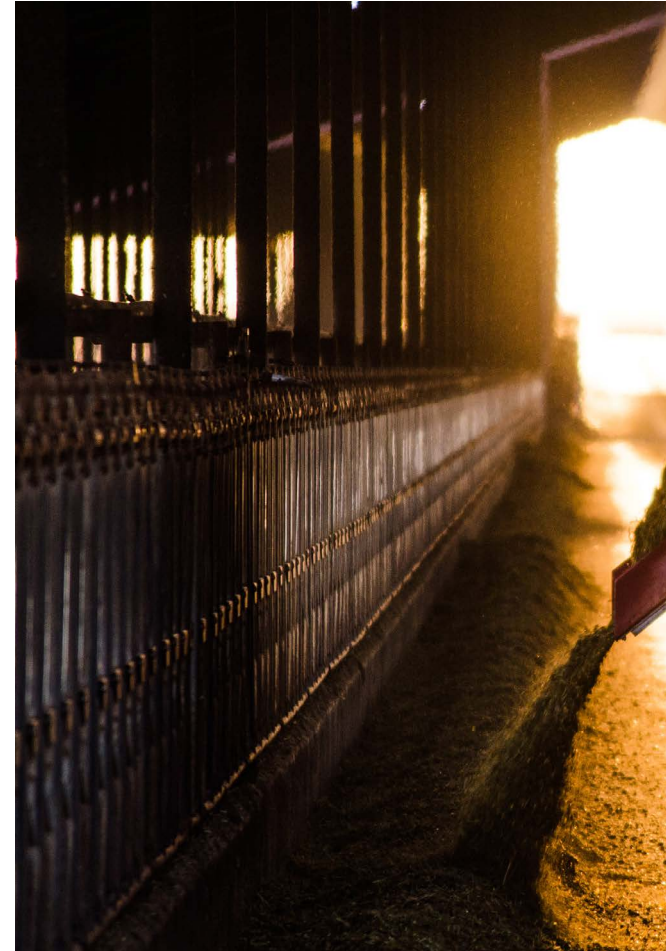



BUILD IT YOUR WAY SUPREME OPTIONS TO CUSTOMIZE YOUR MIXER



10" Industrial Belting Extension

Supreme uses the industry's most durable HD 1/2" belting incorporating a double reinforcing layer along both sides of the tub, for more rigidity to prevent collapse during loading. This industrial strength belting will control spillage when processing rations with a high percentage of roughage.



Side Door Options

Supreme offers multiple side door configurations on single auger models, along with twin models 900T and up, ask Supreme about different configurations available.



Commodity Door

This convenient door with fixed chute and indicator gauge is designed for quick and easy unloading of batch commodities. Available on most Supreme mixers.



Tub Liners

Designed to provide protection against tub wear and abrasion where you need it most. These liners are available in AR 200 or 12GA 302 Stainless Steel and are welded directly to the interior wall of the tub and/or floor.



Tail Lights

Supreme's tail lights are designed to be easily retrofitted on 2015 models and up. These bolt on kits are convenient and have multiple width settings.



Hard Facing Package

Supreme's hard facing is available either on the augers, or as a package on the augers, doors, and baffles. The hard facing is a great way to maximize the life of the high wear points at minimal cost.

CONVEYOR OPTIONS

AVAILABLE ON MOST PULL-TYPES AND TRUCK MOUNTS



Flat Conveyor

Available in 8' & 10' lengths, Supreme Flat Conveyors feature SS Top Pans, 2082 Roller Chain and are 36" wide, providing fast and accurate feedout.



Dual Discharge

Supreme Conveyors can feed out on either side if selected, providing more feeding options. 8' conveyors require a swing gate for Dual Discharge.



Hydraulic Folding Conveyor

The Supreme folding conveyor allows the operators to discharge at several different heights, folding 90 degrees upright when not feeding.



Dogleg Conveyor

The Dogleg Conveyor elevates the discharge height on one side, providing higher ground clearance and bunk feeding much easier.



Extended Dogleg Conveyor

The Extended Dogleg provides an additional 17" extension to the standard dogleg conveyor.

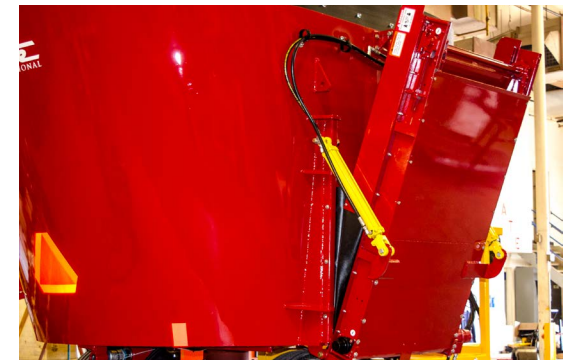

Side Door Conveyor

On single auger side door units, 21" Fixed and Hydraulic Fold Up conveyors in 36", 44", 72", and 96" configurations are available for heightened feed discharge. Only available on single auger pull-type models.

ACCESSORIES



Drop Chutes

Designed to provide more accurate placement of your feed, this drop chute is easily bolted onto the unloading conveyor.

Fixed or hydraulic folding drop chutes are available.



Supreme Swing Gate

The Supreme swing gate allows for dual discharge feeding on 8' conveyors. The swing gate prevents feed from spilling off the conveyor without an end shield.



Hydraulic Extender Kit

The Hydraulic Extender Kit Allows users to operate conveyor from inside the tractor cab without stopping to adjust position.

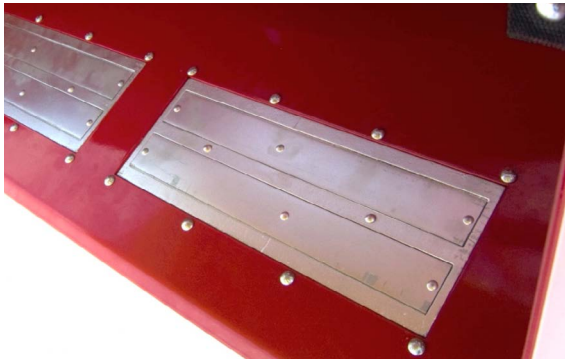

Magnetic Drop Chute

Magnetic Drop Chutes give producers peace of mind, minimizing hardware poisoning.



Bolt on Magnet Kit

The Bolt on Magnet Kit is available so a user can place the kit anywhere on conveyor shields desired.



Auger Magnets

Magnets placed near the bottom of the auger to remove hardware during mixing.



Selector Valves

Supreme Manual and electric function valves allow a user to split a tractor's existing circuit to accommodate more hydraulic functions. Available in 2 function manual, and 2,3, and 4 function electric.



CV PTO

The optional Constant Velocity PTO is designed with a patented ball and socket design and lubrication system, and a patented articulated guard system for maintaining full coverage up to 80 degree angles. All Supreme Pull-Type Feed Mixers come standard equipped with PTO Shafts featuring Free Motion Hub and Auto-Lock Slide Collar design for easy hook-up.



Variable Frequency Drive

Our mechanical stationary units can be powered more efficiently by a Variable Frequency Drive (VFD). Lower startup power, controlled acceleration and adjustable operating speed are just a few of the benefits gained when running a VFD drive.



Autoshift 2 Speed Transmission (1000T+)

Zuidberg is an industry leader in HD transmission applications, and makes significant strain reduction on large, heavy loads.

It will automatically downshift to reduce load on the tractor, and automatically upshift to maximize mixing efficiency.

Also available with a wireless shift controller.



2 Speed Gearbox

For lower horsepower tractors, a two speed gearbox is available which lowers the machine's horsepower requirements by 20%, and provides additional power when required for tougher materials.

Standard Hydraulic Shift with Manual Override. Available on 500/600 600T-1200T



FEPTO Drive

The Supreme Front Engine PTO drive (FEPTO) on Gen 3 truck mounts provides users with lower truck costs and improved access to the drive system for easy maintenance.

DRIVELINE OPTIONS

FRAME OPTIONS

AVAILABLE ON MOST PULL-TYPES



Supreme Small Hitch
Standard on
300/400/500/600/500T



Supreme Large Hitch
Standard on 500T-1400T



Supreme 3 Bolt Hitch
Available on 1000T-1700TR



PPI-301
With Clevis & V Block
Available on 400T-800T



PP40XL
Clevis or V Block
Available on 900T-1400T



Articulating Hitch
Available on 500 - 800T
Comes with a 1", 1-1/4" and 1-1/2" Pin
Size Insert



Articulating Hitch
Available on 900T - 1900TR
Comes with 1-1/2" & 2" Pin Size Inserts



Flotation Tire Upgrade
Upgrade to one of Supreme's flotation tire and wheel packages and you will be ready for varying types of terrain conditions from rough to soft and muddy.



Tandem Axle Walking Beam
Supreme's walking beam is designed to distribute and carry the weight of the mixer through the tandem axle easily and effectively. Available on 900T-1900TR.



Hydraulic Jack
The Hydraulic Jack can lift any Supreme mixer quickly and efficiently.



STANDARD CUTTING AUGER/CORN AUGER

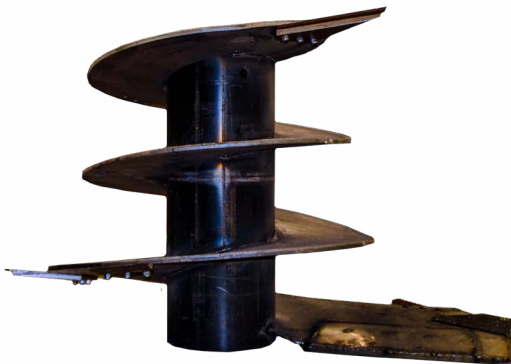

The standard cutting auger pictured above is taller with an additional 1/2 row of flighting, and comes standard with knives.



The corn auger is pictured above with wider flighting and a steeper pitch. It comes standard without knives, but with piercings for the availability of adding them.

In addition to our standard Cutting Auger, users also have the option of a Corn Auger. The Corn Auger is designed to be a gentle and effective auger for the purpose of flaked corn feeding, which equals or surpasses the performance of a horizontal mixer and increases the capacity considerably. The reason being is that our auger speed turns at 32 rpm compared to the horizontal mixer auger speed of 18 – 20 rpm.

Other vertical auger manufacturers cannot handle flaked corn without causing damage to the corn.

ENVIRO MIXER SERIES

All Enviro Series come standard with Hard Faced Augers, high quality Axalta blue paint, AR200 backing plates, and carbide insert knives.

Enviro series are available as pull-type, stationary and truckmount models in Standard Duty (SDE), Heavy Duty (HDE) and select models in Xtreme Duty (XDE) configurations.

For Enviro units, depending on application, Supreme International may recommend a higher horsepower than in feeding applications. Contact Supreme for more information.

SDE

STANDARD DUTY CYCLE

Our standard mixer is the most versatile option for daily processing.

All Model Sizes

Configuration:

- Abrasion Resistant Tub Walls
- Supreme Abrasion Resistant Augers with Hard Facing
- Carbide Insert Knives
- Supreme HD Backing Plates
- Oversized Planetary Gears

Available Upgrades:

- Hard-faced Doors & Baffles
- Auger Magnets

Warranty:

- 3-Year Drivetrain

HDE

HEAVY DUTY CYCLE

The heavy-duty mixer is built for maximum uptime and best suited for larger operations requiring longer mixing cycles.

All Model Sizes

Configuration:

- Abrasion Resistant Tub Walls + 3mm 3CR12 Wall Liner
- Supreme Abrasion Resistant Augers with Hard Facing
- Carbide Insert Knives
- Supreme HD Backing Plates
- Oversized Planetary Gears

Available Upgrades:

- Auger Magnets
- 3mm Stainless Steel Auger Liners
- 3mm Stainless Steel Tub Floor Liner

Warranty:

- 3-Year Drivetrain

XDE

XTREME DUTY CYCLE

Engineered for scale, the XD is the most robust mixer made by Supreme and meets the demands of commercial operations.

900T and Larger Models

Configuration:

- Abrasion Resistant Tub Walls + 5mm 3CR12 Wall and Floor Liner
- Supreme Abrasion Resistant Xtreme Duty Augers with Hard Facing
- Carbide Insert Knives
- Supreme HD Backing Plates
- Oversized Planetary Gears
- Auger Magnets

Available Upgrades:

- 3mm Stainless Steel Auger Liners

Warranty:

- 3-Year Drivetrain

Turn waste into profit.



SUPERIOR WASTE MANAGEMENT



Woodwaste



Mortalities



Vegetable/Food Waste



Biosolids



Reduce Your Processing Time Up to 50%

Every Supreme Enviro Mixer is equipped with Supreme's patented auger design. Employing four separate patents, the Supreme will cut and mix materials simultaneously and can reduce your daily workload by up to 50% over other vertical mixers, while delivering the most accurate and thorough mix in the industry.

Cut and Process Your Most Difficult Materials all in One Machine

Other composting methods use a separate grinder, blender, and debagger. This process is costly and inefficient. Supreme's patented vertical auger design provides unbelievable performance by allowing all three operations to be done simultaneously, saving time and money for the facility.

A Model for Every Size of Operation

From our single auger mixers, that range in size from 231 ft³ - 534 ft³, to the more aggressive twin and triple auger mixers, that range from 479 ft³ - 1,873 ft³, Supreme manufactures a model for every size and type of operation. Supreme mixers are available in Pull-Type, Stationary, and the more mobile Truck Mounted units. All are manufactured utilizing Supreme's patented auger design and only the highest quality components in the industry.

Achieve a Higher Quality Mix and a More Consistent Product

With a Supreme Enviro Mixer the operator will have the ability to cut and blend various waste materials such as green waste, vegetable waste, biosolids, mortalities, and wood waste in any combination. The result will be a thorough and accurate mixture with a consistent and even distribution of moisture and porous materials throughout the entire mix. All of this results in a quicker composting process and a more consistent product.

Supreme Enviro Mixers will improve uniform decomposition throughout the entire pile, resulting in shorter retention time in the composting channel. By reducing time, annual output increases resulting in higher efficiency and profits.



Supreme
INTERNATIONAL
300



DG 500

FEATURES & ADVANTAGES

- WiNET™ port standard for connection of ALL wireless accessories
- Double LCD display that allows a better user interface with clear operator messages
- Multi-language management of the user messages and the menu
- Programs can be set by TOTAL or by NUMBERS OF COWS
- The Change of the TOTAL WEIGHT or the NUMBER OF COWS can be set before the start of the execution, so as to have a program that is always lined up with the needs of the animal
- 2 specific menus for Recipes and Distribution programs
- DTM Suite compatible (DTM Light recommended)
- Upper Display: 6 digit LCD 45 mm to show the weight
- Lower Display: number of digit variable in function of characters visualized on 3 rows
- **24 Recipes each having max 18 Components**
- **24 Distribution Programs each having max 18 Distribution points (pens)**
- **Choice of the Component from a list of 48**
- **Choice of Distribution point (pens) from a list of 48**
- **Accessories connection**



DG 600

FEATURES & ADVANTAGES

- All the features of DG400 and DG500
- Multi-language management of the operator messages (see the table on technical sheet)
- Mixing Timer Control at the load end for the best TMR
- Component accumulation data is recorded internally
- DTM Suite compatible (DTM Advanced recommended)
- Recipe, Distribution program can be set by total weight or by number of cows
- Lower Display: number of digit variable in function of characters visualized many rows
- **99 Recipes each having max 24 Components**
- **48 Distribution programs each having 48 Distribution points (pens)**
- **Choice of the Component from a list of 99**
- **Choice of Distribution point (pens) from a list of 64**
- **Accessories connection**



DG 8000- IC

FEATURES & ADVANTAGES

- 48 Recipes, 24 Components each (from a list of 99 components)
- 96 group of animals (pens), 16 rations each
- 64 nutrition process (batch), 48 groups of animals each
- Recipe formulation based on daily dry matter intake for each pen
- Premix management
- Refusal management by pen
- Specifically designed for integrating NIR Analyzers
- Monitoring operators' labor effectiveness
- Suitable for automatic feeding plants
- Compatible with the DTM Daily TMR Manger Software IC version
- Mixing time control with automatic start at the end of loading procedure
- Managing components/pens even by percentage
- Wireless data exchange between indicator and DTM software via the 3G or WiFi modem
- Recipes can be set by weight, number of cows or by percentage
- The real TMR weight can be set right before distribution. This enables the automatic redistribution of TMR weight for each pen
- The operator can edit name of Components, Distribution Points and Programs in different languages
- Menu and user messages can be displayed within a vast number of languages available
- Total weight, number of cows and percentage adjustment can be changed right before starting the feeding program execution
- Internal diagnostics for checking all device functions (display, load cells signals, buttons)
- Component consumption counter
- **SERVICE FUNCTIONS**
- Working hours counter
- Feed Mixer overloads monitor



DG STAD 02

FEATURES & ADVANTAGES

- LCD display
- Multi-language management of the user messages and the menu
- **Accessories connection**



DG 400

FEATURES & ADVANTAGES

- Overload control for improved operator security
- Working mode: total/partial and get/gross weight
- WiNET™ port for plug & play connection of all accessories
- All models of load cells can be connected



EXTRA DISPLAY

Led display used for the remote weight visualization and the operator messages.

It is especially indicated to allow the operator a constant control of weight as well as component name also at high distance.



FARMCHEF is a mobile scale App available for Android.

Use it on the front loader during loading phase or either in the cab of the tractor during feed distribution. Connect the gateway to the DG500 or DG600 indicators to start using the App and join a faster and interactive feeding experience.

FARMCHEF features

- Managing rations, load and distribution with maximum flexibility
- Managing recipes before feeding and components and pens during the execution phase
- Possibility to modify the database or keeping changes in memory for the current execution
- Weight traceability of refused feed
- Feeding process based on creation of batches, load and distribution managed as single process
- Keep working after a mobile breakdown thanks to connection with the weight indicator

DTM SOFTWARE

DTM Suite Features	DTM Light	DTM Advanced	DTM Professional	DTM IC
Ingredient definition with costs traceability	•	•	•	•
Diet/Recipe definition	•	•	•	•
Distribution definition	•	•	•	•
Loading/Unloading History limited	limited	•	•	•
Detailed reports limited	limited	•	•	•
Graphs				•
Stock management		•	•	•
Driver traceability (only TopScale Indicator)			•	•
Scheduling of programs			•	•
Refused management			•	•
Operators management			•	•
Groups of animals management			•	•
Pen/Batch management				•
Manual Dry Matter adjustment		•		
NIR registries			•	•
NIR historical data			•	•
Automatic Dry Matter adjustment (dg precision FEEDING)			•	•
Livestock scale interface (TAURUS)			•	•
Herd/Milk/Beef management sw interface				•
Truck scale interface (DINA3)				•
NIR Analyzer interface (AgriNIR)				•
Data exchange Computer-Indicator using Memory Card	•	•	•	•
Wi-Fi Data exchange (Computer-Indicator)			•	•
CLOUD	•	•	•	•
Local Installation		•	•	•
DTM Suite: High Performance Platform	•	•	•	•
Multi user profiles management		•	•	•
Multi Language Interface and Setup	•	•	•	•
Contextual Help Online	•	•	•	•
Sw Upgrade via Internet	•	•	•	•
iPhone/iPad/Smartphones compatibility	•	•	•	•



DTM is feeding management software developed with farmers in order to satisfy their needs. DTM is the evolution of a feeding software management as a professional, user friendly and integrated solution for farmers. All farm activities are controlled with a single innovative tool. An easy way to monitor and decrease costs and increase profits.

FEATURES & ADVANTAGES

- Accurate control of feed costs, dry matter intake and refusal management
- All processes are traceable, starting from raw material storage up to ration quality control/check
- DTM software is flexible, friendly and allows better management of raw materials due to accurate loading
- Full control of feeder(s) work
- Accurate control of operations means more productivity and financial benefits for the farm
- Control stock and purchasing planning at best
- Detailed data report and graphs for statistical control
- Ability to take actions in advance
- Feed Efficiency ratio (quantity of milk per cow per day/ quantity of dry matter per cow per day)
- Wifi wireless communication with no distance limits
- Cloud-based system to store data on a remote server making it impossible to lose data.
- Access available from your smartphone or tablet



EZ 2500 V - Simple, Durable, and Easy-to-Use

Provides basic weighing system functionality.

- Large 1.7" (43mm) "chip-on-glass" display retains clarity even when viewed from the sides
- The slimline profile of the EZ 2500 V takes up less space
- TARE, NET/GROSS, & ZERO keys to control weighing functions
- HOLD key to "freeze" the displayed weight when moving equipment
- Optional: Remote and Serial ports for Remote Displays, Printers, or wireless communication via Digi-Star ERM modules.



EZ 2805 / 2810 BT - Added Functions to Improve Loading and Unloading Efficiency

Enhanced functionality with a brighter, high-contrast display!

- Large 1.7" (43mm) white backlit COG is even easier to read than the EZ 2500 V
- Bluetooth connectivity for Topcon FEED app
- Preset Weight function provides improved accuracy and management of loading and unloading
- Internal "alarm light and horn" alert operator of approaching target preset weights
- Rotation Counter / Timer, a Digi-Star exclusive, significantly aids in controlling mix time and processing
- Machine Hour Meter records total operating time and Maintenance Message for service reminder functions (when used with Rotation Counter)
- Optional: Remote and Serial ports, Internal and External wireless communication, External alarm



TMR 3610 - Feed Management Indicator

Advanced full management capability and USB or RF DataLink™ bi-directional data transfer.

- Program rations at your PC or from the front panel of your indicator
- Compatible with TMR Tracker®, Beef Tracker Feed Management Software and third-party bunk read programs
- Internal "alarm light and horn" alerts operator of approaching target weights
- Make "pen call weights" and "head count" changes at the indicator
- Keeps up-to-date feed changes or reuse data from day-to-day
- Help messages in 11 languages
- Optional: Rotation Counter, external light and horn



EZ 400 - Small, Compact and Reliable

Ideal for small indoor stationary mixer applications.

- Tare Key and Net/Gross Key allow for quick display viewing
- Four mounting bracket options: standard, wedge, u-bolt, and RAM for greater flexibility
- Front panel programmability for basic set-up and calibration
- Backlit display



Cab Control™ Wireless remote display and control system from the loader cab that works seamlessly with the mixer scale indicator. Wireless communication and operation of all indicator functions on the feed mixer.



Remote Display RD 2500V

- Large 1.7" LCD display with alarm light
- Bright LCD backlight for dark or inclement conditions
- Slimline profile



Remote Display RD 4000

Large 4" LED bright display

- Visible from 200 feet
- Lighted load progression bar graph
- Visor is available as an accessory

TAP FEED Lite

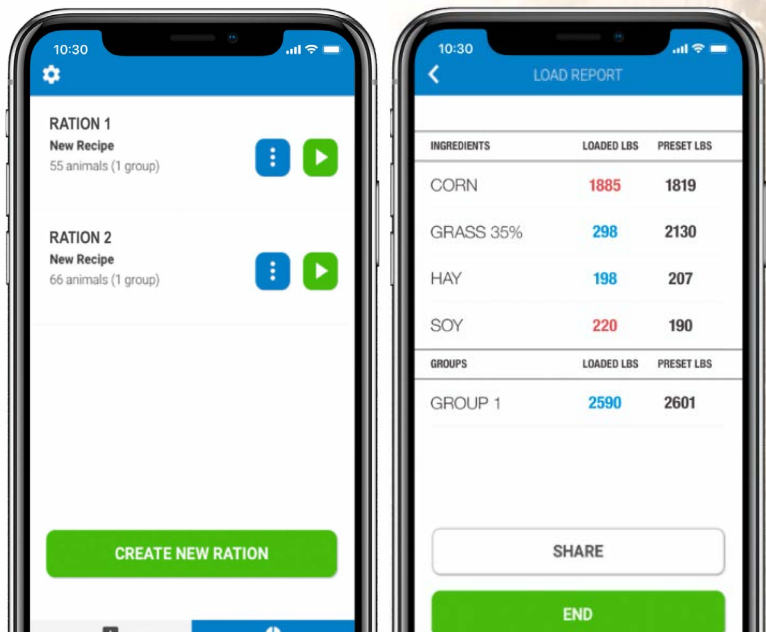

A modern, intuitive, and connected feed management software solution for dairy and livestock operations is here. The latest evolution from Topcon – TAP FEED Lite is fully integrated with a feed mixer scale to drastically improve workflow efficiencies and provide essential feed management data and functionality for today's feeding operations.

- 90-Day Free Trial
- Compatible with Topcon's line of Digi-Star Bluetooth indicators
- Compatible with existing USB Topcon line of Digi-Star indicators

TMR Tracker Functionality by Levels

TMR Tracker Function	LITE	PRO	PRO +
Easy to use Windows® based program	x	x	x
Communicates with EZ3600V, 4600V, 3610 & 4610 Indicators and the TST 7600	x	x	x
Input ingredients and track costs	x	x	x
Input recipes and monitor feed costs	x	x	x
Easy adjustment of Dry Matter values	x	x	x
Calculates Dry Matter Intake	x	x	x
Create recipes on a lb/load, lb/animal or percentage bases	x	x	x
Automated Report Export	x	x	x
Change "Pen Call Weight" and "Head Count" at indicator	x	x	x
Compatible with consultant & online versions	x	x	x
Ingredient usage report	x	x	x
Total # of reports	10+	15+	25+
Operator accuracy monitoring	Limited	x	x
Flexible workday definitions		x	x
Mixer rotation counter & mix time monitoring		x	x
Feed refusal/weighback tracking		x	x
Report writer offers report customization		x	x
Graphical reports			x
Interface with most herd management programs		x	x
Inventory monitoring & forecasting		Limited	x
Predicts feed reorder dates			x
Milk production tracking			x
Calculate Income over feed costs			x
Premix options		x	x
Upgradable to next program level	x	x	
Interface with the Moisture Tracker			x

TMR Tracker

- A Windows® based Feed Management System allowing producers to easily monitor the day-to-day feeding process. TMR Tracker helps manage feed inventory and provides the option to share feeding data with the farm's management team.
- There are three levels of TMR Tracker to meet your operations needs: Lite, Pro and Pro+. (see Functionality by levels chart)
- Help Desk is included with first year's purchase, providing 24/7 software & hardware support.
- Works with most herd management programs to import head counts and milk weights
- Easily monitor and customize the feeding process from start to finish
- Empower your team by providing ease of use and accuracy





QUALITY AND PERFORMANCE THAT STANDS OUT **WORLDWIDE**

Supreme has earned the reputation of being the World's Best TMR Mixer by operating under the most demanding conditions around the world, day in and day out. Contact Supreme at 1.800.563.2038 or visit our website at supremeinternational.com to find out how a Supreme can help your operation and to find your local dealer.



1.800.563.2038 supremeinternational.com

SUPREME FOR A REASON