

FENDT

FENDT 600 VARIO SERIES



FENDT® 600 VARIO SERIES | 149 TO 209 HP RATED

STACKED FULL OF BENEFITS.

Whatever you need, it can probably be found inside a Fendt 600 Vario Series tractor. Here's how:

Power and performance:

- Power segment 149–209 hp (+15 hp for each model thanks to the DynamicPerformance concept)
- New generation engine from AGCO Power™—AGCO Power CORE50:
 - First 4-cylinder engine with up to 224 hp incl. DynamicPerformance
 - 5.0 L capacity
 - Optional reversing fan
- Four-speed rear PTO
- Fendt iD™ low-speed concept (*nominal engine speed: 1,900 rpm*)
- Extremely low fuel consumption thanks to Fendt iD technology

True driver command:

- VarioDrive drive train with variable four-wheel drive
- **New generation front loader:** Fendt Cargo 4.85, 5.85 and 5.90
- Row crop or metric tire configurations available
- Optional VarioGrip™ tire pressure control system

A cab with vision

- VisioPlus cab
- Outstanding view with 77° upward viewing angle, 72% all-round visibility index as well as windshield wipers with up to 300 degrees (*front*) and 97 degree side wipers

Our FendtONE operating philosophy:

- FendtONE™ operation and user interface
- Simple and intuitive controls for ease of use

Engine	614 Vario	616 Vario	618 Vario	620 Vario
Rated Engine Power (HP / kW)	149 / 110	169 / 124	189 / 139	209 / 154
Max Power w/DP ECE R 120 (HP / kW)	164 / 121	184 / 135	204 / 150	224 / 165









THE FENDT 600 VARIO HIGHLIGHTS

Fendt Spotlight #1—Ultimate Drivetrain for a Perfect Drive

Here's what our completely-new, intelligent stepless drive technology brings you:

- A powerful, robust and compact 4-cylinder engine*
- A combination of low-speed, low-rev concept (*Fendt iD*) with comprehensive DP added performance and maximum availability of additional power via DynamicPerformance.
- An efficient drive train, with automatic four-wheel drive, for maximum tractive power and superior ground protection on any surface.
- A fully-integrated, tire pressure regulation system (*VarioGrip*) for up to 10% more tractive power* and 8% less fuel consumption**

* The 620 Vario offers maximum torque of up to 950 Nm at 1,200–1,600 rpm and it's well above the average of current comparable 6-cylinder engines in the 200 hp class.

** Investigation at the South Westphalia University of Applied Sciences of Agricultural Economics in Soest—VarioGrip—Save more than just money with the right tire pressure—YouTube, www.fendt.com/us/technologies/fendt-variogrip

Fendt Spotlight #2—Unmatched Payload, Maneuverability and Performance

In the 200 hp tractor class, there's nothing like it, including:

- A frame concept designed for maximum strength that allows a payload of 12,787 lbs. (5,800 kg)
- Pull-in turn effect pulls the machine into the turn instead of the negative influence on the turning circle caused by conventional rigid four-wheel drive.
- Smart and automatic power distribution with maximum soil protection during field and front loader work.

Fendt Spotlight #3—Clearer Driver Experience

With superior visibility and control, drivers will find:

- A 77-degree, upward viewing angle, driver all-round vision index of 72%, low-vibration and quiet workplace
- Trailer brake assistant for more control with pneumatically braked trailers
- Optional ErgoSteer joystick steering for fast turning and relaxed working on headlands and front loader work



Fendt Spotlight #4—Nimble Tractor, Big Overall Package

This tractor packs a punch, offering:

- Maximum payload and outstanding maneuverability
- VarioDrive with automatic, tension-free four-wheel drive



HEAR ALL ABOUT OUR NEXT GENERATION ENGINE.

Maximum torque?

Achieved at a low 1,200–1,600 rpm. That's impressive performance with remarkable fuel efficiency!

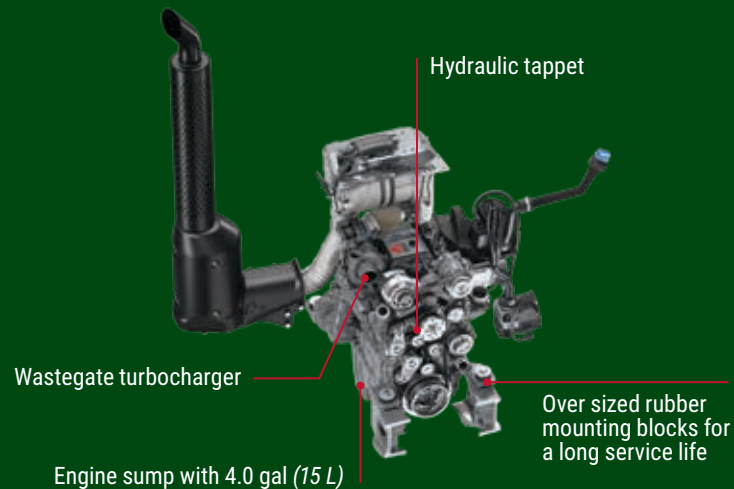

The AGCO Power CORE50. Enough said.

With its 4-cylinder, 5.0-liter capacity power plant is focused on more torque and less fuel consumption. Enjoy Fendt iD low engine speed concept—speed range from 800/950 rpm (*idling*) to 1,900 rpm (*rated speed*) with DynamicPerformance (*DP*) concept for all models and an electronically-controlled wastegate turbocharger.

It's cleaner too, and compliant with the limit values for exhaust gas regulations and TIER 4 final. You'll find hydraulic tappets for automatic valve lash adjustment and a smooth, low-vibration engine running.

If it's power and torque you want, it's power and torque you'll get.

With the addition of DynamicPerformance across all models in the Fendt 600 Vario Series, this tractor delivers up to an additional 15 horsepower per model.

There's also Fendt iD low-speed concept with high torque of 701 ft-lbs. (950 Nm) even at low engine speeds, with a range of only 800 (*idling*)–1,900 rpm (*rated*). Fendt iD's reduced engine speed will result in low fuel consumption, low noise level and less wear.



Need torque? It offers full torque curve and full torque from 1,200 rpm an engine perfectly matched to the VarioDrive drive train. You'll achieve max speed at reduced engine speed with 31 mph (50 km/h) at 1,300 rpm.

A fan that keeps it all moving.

Optimal for dusty conditions, this engine offers an optional adjustable reversible fan function, suction fan and cooling concept.

For maximum efficiency, the optional adjustable, reversible fan function allows independent cleaning of the radiator grill. Reversing is enable by adjusting the blades and it's all controlled via oil medium instead of air medium.

On the suction fan, it's an electronic, Visco-fan with a clutch that controls fan speed as required. Lastly, there's minimum clearance between fan blades and cover, and each cooler can control the fan separately.

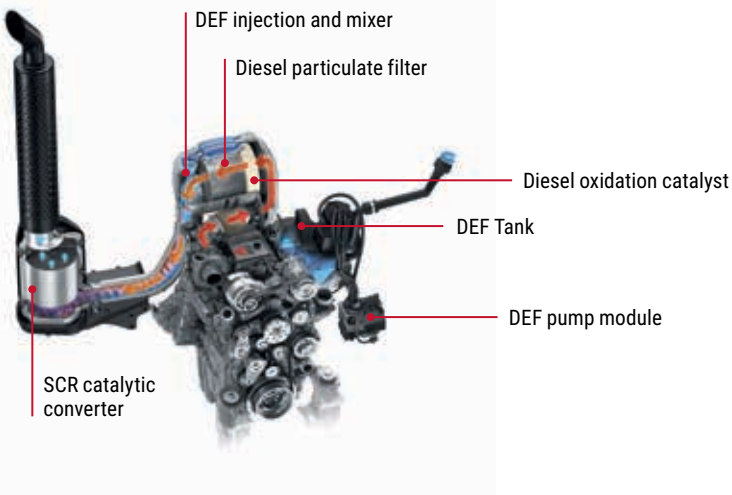

FENDT DYNAMIC PERFORMANCE (DP)

Welcome to Fendt DP, an intelligent, extra power concept that ensures consistent work performance and translates to 15 hp more power for all Fendt 600 Vario models.

What makes it intelligent multi-performance?

Engine power that feeds numerous auxiliary consumers in addition to main consumers: whether in tillage, PTO work, transport or PTO work when stationary.

Known boost concepts with numerous restrictions in practical use only available in narrowly-defined application situations.

Main consumer vs. secondary consumers

Main and auxiliary consumers mean tractive power at the wheels, a PTO shaft that drives corresponding devices, and a hydraulic pump that drives equipment or controls functions. While secondary consumers, such as fan, air-conditioning, alternator and air compressor, are also served.

Power demand from auxiliary consumers reduces the available power for traction, PTO and hydraulic work.

What are the results?

We offer an intelligent, sensor-controlled solution independent of fixed parameters, such as speed as well as additional availability of the intelligent extra power even when cultivating the soil at low speeds and when stationary compared to conventional boost concepts. Get more area output and less fuel consumption.

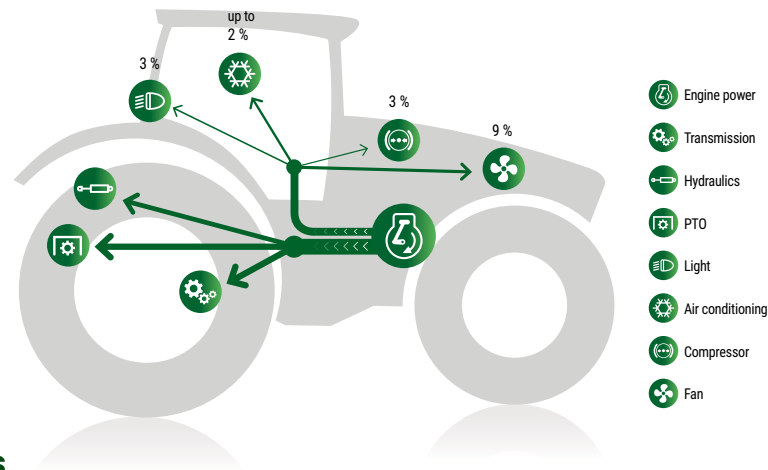



SHIFT YOUR EXPECTATIONS WITH FENDT VARIODRIVE

The revolutionary VarioDrive transmission gives you independent drive of front and rear axle, intelligent four-wheel drive, elimination of drive range shifting and much more. Already proven in our larger tractors (*Fendt 700 Vario Gen7, 900 Vario and 1000 Vario*), the Fendt 600 Vario available for the first time in this power class.

With separate hydraulic motors for front and rear axle, which act on the respective axle, perfect combination of maximum tractive power, maximum ground protection, and outstanding maneuverability in every situation.

Power where you need it.

The Fendt VarioDrive transmission means fully automatic power distribution between front and rear axle with intelligently controlled, independent four-wheel drive for improved handling on slippery surfaces, more soil protection, more pull-in-turn effect for better maneuverability while cornering, and less tire wear.

Say hello to independent four-wheel drive.

Because the front axle “pulls” the tractor around the curve, the effect is like a “pull-in-turn” and gives you about 10% more turning radius than a comparable tractor.

Full road capacity and PTO options to get the job done.

This tractor gives you torsion-free all-wheel drive, even on the road and when cornering. You won't lose power, either between the front and rear axle, so there's less tire wear and fuel consumption. Enjoy automatic comfort with perfect four-wheel drive technology: single-stage driving concept without shifting wherever you go.

We put intelligence first.

This tractor brings drivers the peace of mind knowing they're always using the best drive technology. There's no travel range switching. In short VarioDrive, is the perfect symbiosis of maximum tractive power and superior ground protection on any surface without tension and stress for the driver.

VarioDrive design

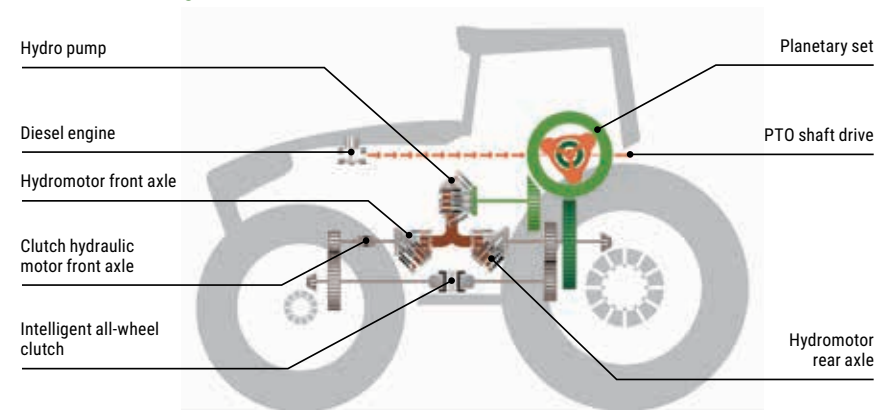



Four-speed rear PTO is ready.

Enjoy more efficiency from the crankshaft to the PTO stub shaft (*only one gear stage in PTO transmission*). There's also electro-hydraulic speed preselection, external operation on both sides of the mudguard and PTO stub detection.

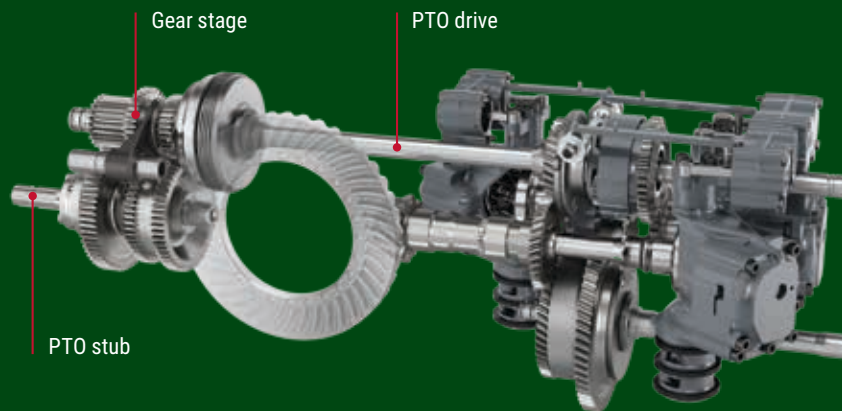

More Details of 4-speed rear PTO also include:

- 540/540E, 1000/1000E
- Standard PTO 540 and 1000:
 - 1,000 PTO revolutions are available at an engine speed of 1,830 rpm
- 540E and 1000E economy PTO:
 - 1,000E PTO revolutions are available at an engine speed of 1,457 rpm

Automatic PTO—at the push of a button.

Want things easier? How about the external actuation of PTO (*start/stop*)? Or speed selection from the cab.

Just switch the rear PTO on and off after you assign to buttons on the drive lever. You can activate PTO on and off automatically at preset positions of the power lift and PTO off point can be set with the rear power lift position.



External rear PTO operation

Starting an adjustable engine speed when activating the PTO on the mudguard

- Fully integrated into the Fendt TI headland management system

HYDRAULICS— SET JUST HOW YOU LIKE THEM.

The Fendt 600 Series offers two different versions: 40.2 gal/min (152 l/min) or 54.2 gal/min (205 l/min) flow rate both with closed center, variable displacement pumps and a large removable oil quantity of 17.2 gal (65 liters).

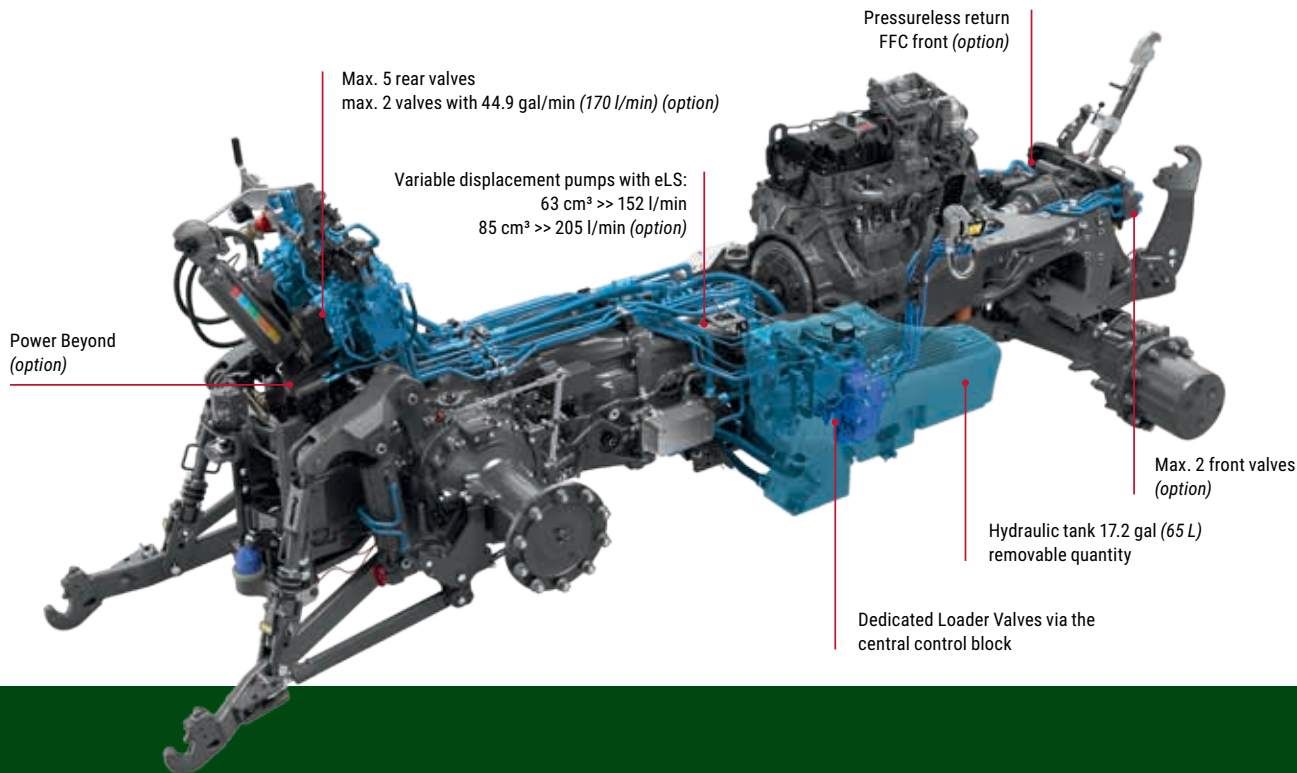

Other features include:

- Separate transmission and hydraulic oil supply for reduced cross contamination
- Optimal ergonomic arrangement of the operating elements for working hydraulics and power lift
- Numerous setting options via the terminal (free assignment of operating locations, time function, oil quantity setting)

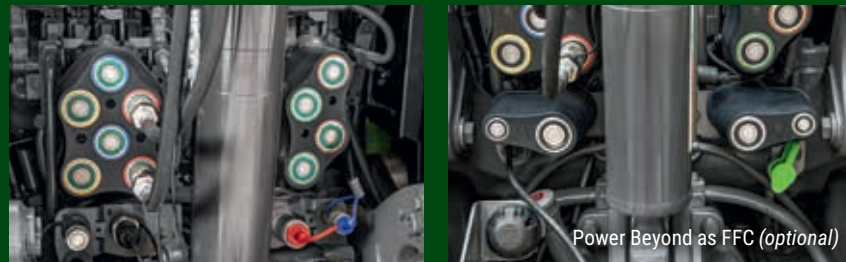

Valve numbers:

- Max. number of valves for Power: A total of max. Six double-acting valves (front 1, center 2 and rear up to 3 for front valve, otherwise, rear max. 4) plus Power Beyond
- Max. number of valves for Profi/Profi+: A total of max. Ten double-acting valves (front 2, center 3 and rear 5) plus Power Beyond

Automatic steering axle lock

This tractor offers automatic locking and unlocking of the trailer steering axle above and below definable speeds. Remember, the steering axle is always locked when reversing and you set the activation and setting of the speed range. Determine the assignment of the hydraulic valve in the terminal and automatic override is always possible.

Rear power lift with Single Acting or Double Acting cylinders

- Cat. 3 Ball Style Link Ends
- Single Acting (SA) standard
- Electronic Position Control (EPC)
- Max Lift Capacity 18,884 lbs. (8,566 kg)

Relief control, under control

Lock your ground-guided implements in three-point linkage to be constantly guided at a constant working height even on uneven and soft ground. Then, follow the ground contour precisely with rear attachment actively via adjustable contact pressure for more efficient results. And always experience higher traction thanks to weight transfer from the implement to the tractor.



Front power lift with three choices of variants

If it's options you want for front power lift, it's options you'll get:

1. Comfort ballast pick-up without front power lift
2. Front power lift (*single acting*) Cat. 2 with position control
3. Comfort front power lift (*double acting*) Cat. 2 with position control and relief control

Regardless of what you chose, this tractor features front power lift fully-integrated into half-frame to keep the unit short for the best maneuverability. There's also folded lower links integrated very close to the vehicle and built-in side protection without protruding lines.

Other details include:

- High front maximum lifting capacity of 9,932 lbs. (4,505 kg)
- Easy attachment of implements with camera in the hood (*optional*)
- Top links with solid brackets and easy handling
- Leakage oil reservoir for auxiliary control units integrated in lower link frame

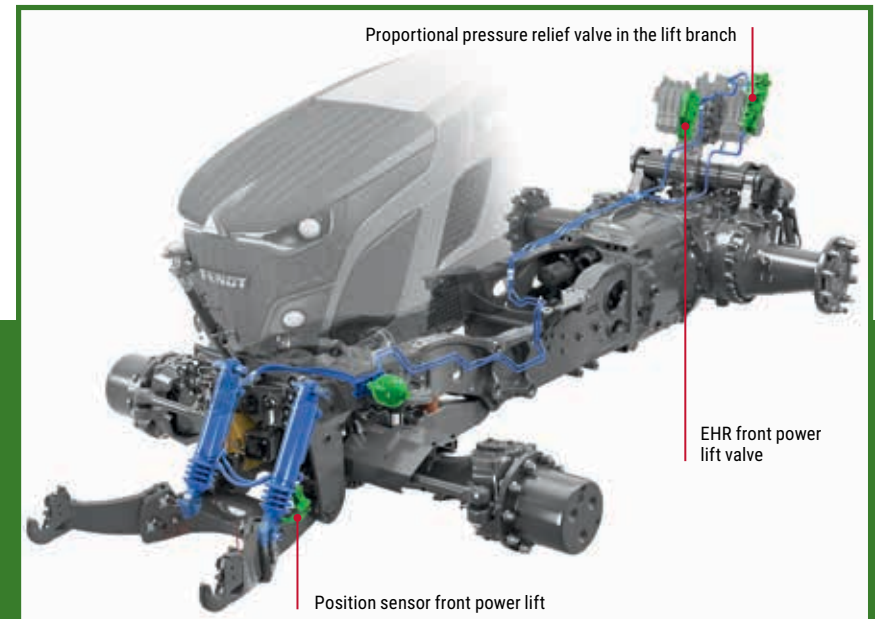



CREATURES, COMFORTED.

The biggest perks

With a continuous field of vision (*77 degrees*), this cab features low noise levels, tons of storage space, infotainment options, automatic air conditioning, cab suspension options, a digital hood and rear camera and tons of other features.

Additional cab features:

- Optional with heated and laminated safety glass (LSG) front window
- Wide and therefore comfortable entry
- Instructor seat with padding and backrest
- Space for optional coolbox and warmer for long working days
- Crossed work lights for glare-free lighting in the dark without shadows
- Pivoting steering column with digital dashboard
- Rear-view mirror with integrated wide-angle component as standard
- Optional: electrically adjustable and telescopic, heated rear-view mirrors
- Automatic air conditioning >> 30% higher cooling under full load
- Optional immobilizer with coded key
- Various suspension systems
- Sun blind at the front, optional at the rear
- Optional side window wiper on right side

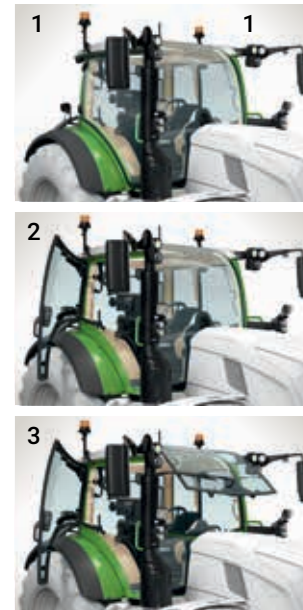

Fig. 1, 2, 3:
Illustration shows a 700 Vario Gen7.



Pneumatic (top)
Pneumatic Comfort (bottom)



How do you like your ride?

Get your choice of cab suspension settings with integrated level control. First, you can keep the standard pneumatic with the two conical bearings at the front and two pneumatic spring elements at the rear.

Your second option is pneumatic comfort featuring a 3-fold pneumatic with a pneumatically suspended, central swing arm at the front, and two pneumatic suspension elements at the rear.

A THRONE FIT FOR ROYALTY.

FENDT 600 VARIO SERIES



Let's face it, you'll be spending many an hour sitting in the cab's driver seat. So, we've made it as comfortable as possible. Enjoy a premium, air suspension seat with longitudinal and lateral horizontal suspension as well as genuine leather upholstery. Plus, it offers electric adjustment of the backrest, side bolsters and lumbar support; electric longitudinal adjustment and a massage function available.



The New Standard in Comfort:

- Integrated memory function saves individual driver settings via the user profile:
 - Automatic weight adjustment and electrical, continuously and automatically height adjustment (*air-supported*)
 - Electric, automatic backrest tilt adjustment
- Automatic lumbar and side bolster support
- Operating and setting the seats comfort functions done via the terminal:
 - Three-stage seat heating and active three-stage seat ventilation (*seat and backrest*)
 - Back massage function
 - Automatic lumbar and side bolster support



Three ways to set your mirrors:

1. Rear-view mirror with wide angle mirror (*mechanically adjustable*)
2. Comfort mirror rear and wide-angle mirrors electrically adjustable, heatable
3. Comfort mirror telescopic: rear-view and wide-angle mirrors electrically adjustable, heatable, and mirror holder retractable and extendable

Infotainment ready

Entertainment and communication includes hands-free equipment, high-quality radio reception, connection of a wide range of external audio sources and fully-integrated operation via terminal or rotary knob on the armrest. Also, it's available with Infotainment Plus, a 4.1 sub-woofer equipped sound system.

Heads-up displays

With a 10.1" digital display affixed to the steering column featuring different display modes, message types, and view settings, you can easily stay on top of everything. There's also a 12" terminal on the armrest, and an optional 12" terminal in the roof, both operable by touch and/or rotary-push dial, and extremely intuitive.

There's also flexible key assignment via IOM (*Individual Operation Manager*) so you can assign key functions at the respective operating location via "drag and drop" in the IOM menu.

TAKE CONTROL ON ANY JOYSTICK.



Choose the standard, multifunctional joystick to control actions like reversing, activation of cruise control and accelerating/decelerating as well as important transmission functions like cruise control preselection, TMS, speed memory, etc. located in the lower side area.

Included with Profi and Profi+, the 3L Joystick is for operation of the 3rd and 4th hydraulic control unit. It's fully ISOBUS-capable and up to 27 functions are distributed over up to three operating levels (3L-3 levels). Whatever you choose, you have the control.



PRODUCTIVITY AT YOUR FINGERTIPS.



WORK SMARTER.

Fendt Guide auto steering and headland management. For those who prefer precision.

You can configure your Fendt guidance system to suit your needs. Equip your system with either a Trimble® satellite receiver or NovAtel®. Depending on your work and individual requirements, you can choose from correction signals with different accuracy levels.

Trimble receiver



6-12 in

Trimble Standard

Correction signal: SBAS (Egnos & Waas)

± 6-12 inches track-to-track accuracy; ± 59 inches repeatable accuracy

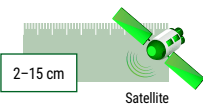

2-15 cm

Trimble – extendible correction signals

Correction signal: RangePoint® RTX

± 6 inches track to track accuracy; ± 19.7 inches repeatable accuracy

Correction signal: CenterPoint® RTX and CenterPoint RTX Fast

± <1 inch track to track accuracy; ± <1 inch repeatable accuracy



2 cm

RTK

Correction signal: RTK

± <1 inch track to track accuracy; ± <1 inch repeatable accuracy

Mobile network / radio

NovAtel receiver



6-12 in

NovAtel Standard

Correction signal: SBAS (EGNOS & WAAS)

± 6-12 inches track-to-track accuracy; ± 59 inches repeatable accuracy

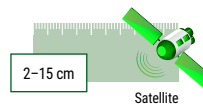

2-15 cm

NovAtel – extendible correction signals

Correction signal: TerraStar-L

± 6 inches track to track accuracy; ± 19.7 inches repeatable accuracy

Correction signal: TerraStar-C Pro

± <1 inch track to track accuracy; ± <1 inch repeatable accuracy

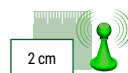

2 cm

RTK

Correction signal: RTK

± <1 inch track to track accuracy; ± <1 inch repeatable accuracy

Mobile network / radio

Because the receivers are installed under the roof hatch, they are fully protected against theft, weather and damage.

Two main factors are decisive for farming:

- Track-to-track accuracy: Shows how precise the contacts are from one track to the next
- Repeatable accuracy: Specifies how accurately you can repeat an existing wayline or field boundary from the previous year

Headland management made easy with Fendt TI and TI Auto

This smart assist is a real benefit for repeat processes, especially headlands. Our Fendt TI headland management system saves you up to 1,920 daily hand movements in 160 turns. Both manually at a standstill and while driving, you can record all the functions as a sequence and save them in the terminal. Later, all it takes is a touch of a button to activate the automated sequences when entering and coming out of the headland. Work without having to reposition. Five triggers (*route, time, front power lift, rear power lift and manual*) and 13 function groups help you control an impressive 74 functions. Shift smoothly between the individual sequence steps. Later, all it takes is a touch of a key to activate the automated sequences at the headland.

With Fendt TI in combination with Fendt Guide (*Fendt TI Auto*), position detection automatically initiates all recorded steps at the headland.

Work profiles for perfectly adjusted equipment, even with different operators working on the same machine

With the work profiles, you can save each implement with its own settings. This saves you from having to enter the settings each time. Even if you have different operators, they can then work efficiently and optimized without adjusting any settings. The numerous setting parameters include: power lift, PTO, hydraulics, maximum load control, cruise control, engine speed, and differential locks.

AGRONOMY.

SAVE TIME IN THE OFFICE.



Fendt TaskDoc: Get ahead of the paperwork

With the order-led documentation system Fendt TaskDoc®, your tractor collects all necessary data as you work. You can then transfer the data as a standardized file into a field map—either via a USB stick, Bluetooth or wirelessly over the mobile network.

MACHINE CONTROL.

Perfect interaction of tractor and implement.



SectionControl (SC)

SectionControl ensures accurate seed or product placement based upon coverage maps.



Perfect interplay via ISOBUS:

SectionControl, VariableRateControl and the Fendt Guide Contour Assistant give you all the software you need for high-precision, quality work.

Fendt ISOBUS is a standardized plug & play interface between the tractor and the attachment: Simply connect the ISOBUS plug to the ISOBUS socket, and the control screen of the attachment appears in the terminal.

Pinpoint precision: Fendt SectionControl

SectionControl provides automated section control for ISOBUS implements. Fendt SectionControl supports up to 36 partial widths. The ISOBUS standard promises intuitive handling: The control screen automatically appears on the terminal when you connect the ISOBUS plug to the socket. All you need to do is activate a switch to start.

How you benefit from Fendt SectionControl

- Savings of up to 15% in resources by avoiding unwanted overlaps
- Reduces the threat of disease, pests and weeds by avoiding overly dense crops and missed sections
- Less effort for the driver, so they can fully concentrate on monitoring the implement
- Improves the quality of work with automatic and accurate swath control
- Headland mode: Option to work the inner field first, then the headland

Make full use of your tractor's potential: Fendt VariableRateControl (VRC)

VRC controls the output volume of resources (*seeds, pesticides, fertilizers*) for each subsection of field. To benefit from this smart solution, you need Fendt TaskDoc and an ISOBUS TC-GEO standard license.

The advantages of Fendt VariableRateControl

- **Increase your efficiency:** Maximize yield while saving resources
- **Save time:** Use the job report as a reporting basis
- **Flexibility:** Compatible with ISO XML and Shape files

No need for an external ISOBUS display

The optional 12" roof terminal offers you even more display space. You can show your ISOBUS attachment data on the roof display, for example, while the display on the armrest shows the lane guidance. External displays are no longer needed.



Fendt Guide Contour Assistant

The Fendt Guide Contour Assistant option adds Contour Segments and Single Track to the familiar wayline types.

Contour Segments wayline

Record each segment and track everything, or apply them directly from the existing field boundary.

- No need to record different waylines to edit different sections of the field
- No need to manually switch between waylines as you work the field
- Combine all relevant tracks in one
- Contour Assistant automatically detects the right track

Single Track wayline

Record an almost endless track with an open contour.

- Ideal for plant protection, as you can record a single track and apply it to the whole field

TELEMETRY. OPTIMIZE YOUR MACHINE USE.



Call up machine data from any location: Fendt Connect

Fendt Connect is the central telemetry solution for Fendt machines. With Fendt Connect, machine data is collected and evaluated, so farmers and contractors can monitor, analyze and optimize the condition and use of their machines.

Fendt Connect tells you about:

- Machine position and route
- Fuel consumption and DEF level
- Speed and working time
- Machine capacity
- Error messages
- Upcoming service intervals

Fendt Connect

Mobile data transmission means you can check your realtime machine data anywhere—from a PC, tablet or smartphone.





TACKLE ANYTHING IN FRONT OF YOU.

The Fendt 600 Vario's front loader is ready to get to work. Add 77° field of vision and outstanding maneuverability, the Fendt Cargo 4 and Fendt Cargo 5 front loader generations, you are ideally equipped for the job ahead.

Dedicated loader valves are included standard to not occupy additional rear valves.

- New multi-coupler:
- 4-hose / 6-hose cross-compatible with each other
 - Less pressure loss
 - Dirt cover

Swing arm with a width of 44.9 in (1,140 mm)

Work lights

- Separate valve block for front loader:
- 3 separate valves (lift/tilt/3rd valve)
 - No shared lines

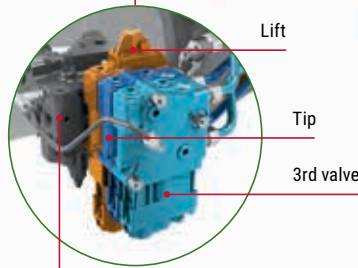

Central control block: two variants (with/without front loader)

3rd valve
3rd circuit

Hydraulic tool locking with locking function (tool change in any position) and mechanical locking monitoring

THE BOTTOM LINE: WE CARE ABOUT YOURS.



GOLD STAR
CUSTOMER CARE



Ever since Sylvester Fendt and his 17th century family of artisan clockmakers built an ironclad reputation for personally servicing and maintaining each clock they installed, we've understood that a great warranty isn't a matter of profit, it's one of pride. The standard Fendt Gold Star Customer Care Program is the best in the business. But our commitment isn't just uptime all the time. It's providing the kind of after-sale care that rewards you with exceptional resale value when you eventually trade in your tractor for a newer model.

The warranty

Three years or 3,000 hours, including all scheduled routine maintenance and all other repairs, as required.

The parts

Fendt dealers use only genuine AGCO® parts, so your Fendt is always 100% Fendt. All parts are covered for one year, and all labor for six months, under the AGCO Parts Advantage warranty.

The service

Fendt dealers and their certified technicians use only the highest-caliber diagnostic tools.

The loaner

If your tractor can't be repaired in 48 working hours* we'll provide you a loaner tractor. We stand by this promise for three years or 3,000 hours.

*Two full 24 hour days



GOLD STAR+
CUSTOMER CARE

Gold Star+ (Optional)

For longer working periods, you can extend the standard Gold Star offering with Gold Star+. All the same benefits but for as long as five years or 5,000 hours.

SPECIFICATIONS

Fendt 600 Vario	614	616	618	620
Rated Engine Power (HP / kW)	149 / 110	169 / 124	189 / 139	209 / 154
Max Power w/DP ECE R 120 (HP / kW)	164 / 121	184 / 135	204 / 150	224 / 165
Rated PTO Power (HP/ kW)	130 / 96	149 / 110	165 / 121	182 / 134
No. of Cylinders / Cooling	4 / Liquid			
Cylinder Bore x Stroke	4.0 in / 5.0 in // 101 mm / 126 mm			
Displacement (L / cu. in)	5.0 / 305			
Rated Speed (rpm)	1,900			
Max. Torque at 1,300 rpm (lb-ft / Nm)	585 / 793	635 / 861	667 / 904	701 / 950
Torque Rise	17% based on 1,700 rpm			
Diesel Tank Capacity (gal. / L)	91.7 / 347			
DEF Capacity (gal. / L)	9.5 / 36			
Oil Change Interval (operating hours)	500			
Transmission Type / Model	ML 150 Vario Drive CVT			
Speed Range	Forward: 65 ft/hr to 31 mph / 0.02 km/h to 50 km/h Reverse: 65 ft/hr to 20.5 mph / 0.02 to 30 km/h			
Rear PTO	540 / 540E / 1000 / 1000E			
Hydraulics	Closed Center / Pressure & Flow Compensated			
Hydraulic Pump Capacity (GPM / L/min)	Standard Flow: 40.2 / 152 Optional Flow: 54.2 / 205			
Aux. Control Valves (front / center / rear)	Power: 1 / 2 / 4 Profi / Profi+: 2 / 3 / 5			
"Flow Volume Control Valves (GPM / L/min)"	High Flow Volume of 36.9 / 140 Std. Opt. 3 and 4 Valve with 44.9 / 170			
Working Pressure	2901 psi + 145 psi / 200 bar + 10 bar			
3-Point	Std: Single-acting lifting cylinders with locking function Option with Profi & Profi+: Double-acting lifting cylinders			
Rear Lift Capacity, hitch point (lb / kg)	18,884 / 8,566			
Front Lift Capacity, hitch point (lb / kg)	9,932 / 4,505			
Unladen Weight (lb / kg)	16,799 / 7,620			17,064 / 7,740
Max. Perm. Overall Weight (lb / kg)	29,762 / 13,500			
Wheelbase (in. / mm)	107.1 / 2720			



FENDT



FENDT
600 VARIO SERIES

 **AGCO** | **AGCO ANSWERS**
Your Agriculture Company | (877) 525-4384 AGCOanswers@AGCOcorp.com

AGCO may at any time, and from time to time, for technical or other necessary reasons, modify any of the data, specifications or warranty of the products described herein. Some equipment shown may be optional. Attention: Photographs in this publication may show protective shields and guards open or removed for the purposes of illustration. Be certain all shields and guards are in place during operation.

©2025 AGCO Corporation. Fendt is a worldwide brand of AGCO Corporation. AGCO®, Fendt®, Fendt Connect™, FendtONE™, Fendt ID™, TaskDoc® and VarioGrip™ are trademarks of AGCO. Bluetooth® is a trademark of Bluetooth SIG, Inc. All rights reserved.

FT25BRC006AG