

# 3080T

## Telescopic wheel loader



**WEIDEMANN**  
*designed for work*



### 3080T Technical specifications

#### Engine data

Manufacturer	Deutz
Engine type	TCD 2.9 L4 S5
Cylinders	4
Engine performance	55.4 (75) kW (hp)
at rpm (max.)	2300 rpm
Cubic capacity	2900 cm <sup>3</sup>
Cooling system	Water / charge air
Emissions standard level	V
Exhaust after treatment	DPF/DOC

#### Electrical system

Operating voltage	12 V
<b>Weights</b>	
Operating weight (standard)	5400 kg
Tipping load with bucket - machine straight	2815 (1554*) kg
Tipping load with bucket - machine articulated	2411 (1300*) kg
Tipping load with pallet fork - machine straight	2570 (1509*) kg
Tipping load with pallet fork - machine articulated	2207 (1262*) kg
<b>Vehicle data</b>	
Axle (optional)	PA 1400 (PA 1422)
Cab	Cabin
Ground speed (optional)	0 - 20 (30) km/h
Speed stages	2
Fuel tank capacity	82 l
Hydraulic oil tank capacity	66 l
<b>Hydraulic system</b>	
Steering hydraulics - Oil flow (optional)	57.5 (73-83) l/min
Steering hydraulics - Operating pressure	235 bar
<b>Drive</b>	
Type of drive	Hydrostatic
Traction drive	Universal joint shaft
<b>Noise values</b>	
Average sound power level LwA	100.3 dB(A)
Guaranteed sound power level LwA	101 dB(A)
Specified sound pressure level LpA	78 dB(A)

\*Tipping load values when extended

Tipping load calculation according to ISO 14397

Vibrations (weighted average effective value)

**Hand-arm vibrations (HAV):** The hand-arm vibrations are no more than 2.5 m/s<sup>2</sup>

**Whole body vibrations:** This machine is equipped with a driver's seat that meets the requirements of EN ISO 7096:2000.

When the loader is properly used, the whole body vibrations vary from below 0.5 m/s<sup>2</sup> up to a short-term maximum value.

It is recommended to use the values specified in the table when calculating the vibration values according to ISO/TR 25398:2006. At the same time the actual use conditions have to be taken into consideration.

Telescopic loaders, like wheel loaders, are to be classified by operating weight.

Average value

Standard deviation (s)

Type of loader	Typical operating conditions	$1.4 \cdot a_{w,eqx}$ [m/s <sup>2</sup> ]	$1.4 \cdot a_{w,eqy}$ [m/s <sup>2</sup> ]	$a_{w,eqz}$ [m/s <sup>2</sup> ]	$1.4 \cdot s_x$ [m/s <sup>2</sup> ]	$1.4 \cdot s_y$ [m/s <sup>2</sup> ]	$s_z$ [m/s <sup>2</sup> ]
Compact wheel loader (operating weight < 4,500 kg)	Load & carry (load and transport work)	0.94	0.86	0.65	0.27	0.29	0.13
Wheel loader (operating weight > 4,500 kg)	Load & carry (load and transport work)	0.84	0.81	0.52	0.23	0.2	0.14
	Application in extraction (harsh application conditions)	1.27	0.97	0.81	0.47	0.31	0.47
	Transfer drive	0.76	0.91	0.49	0.33	0.35	0.17
	V-operation	0.99	0.84	0.54	0.29	0.32	0.14

# 3080T

Telescopic wheel loader

## 3080T Dimensions

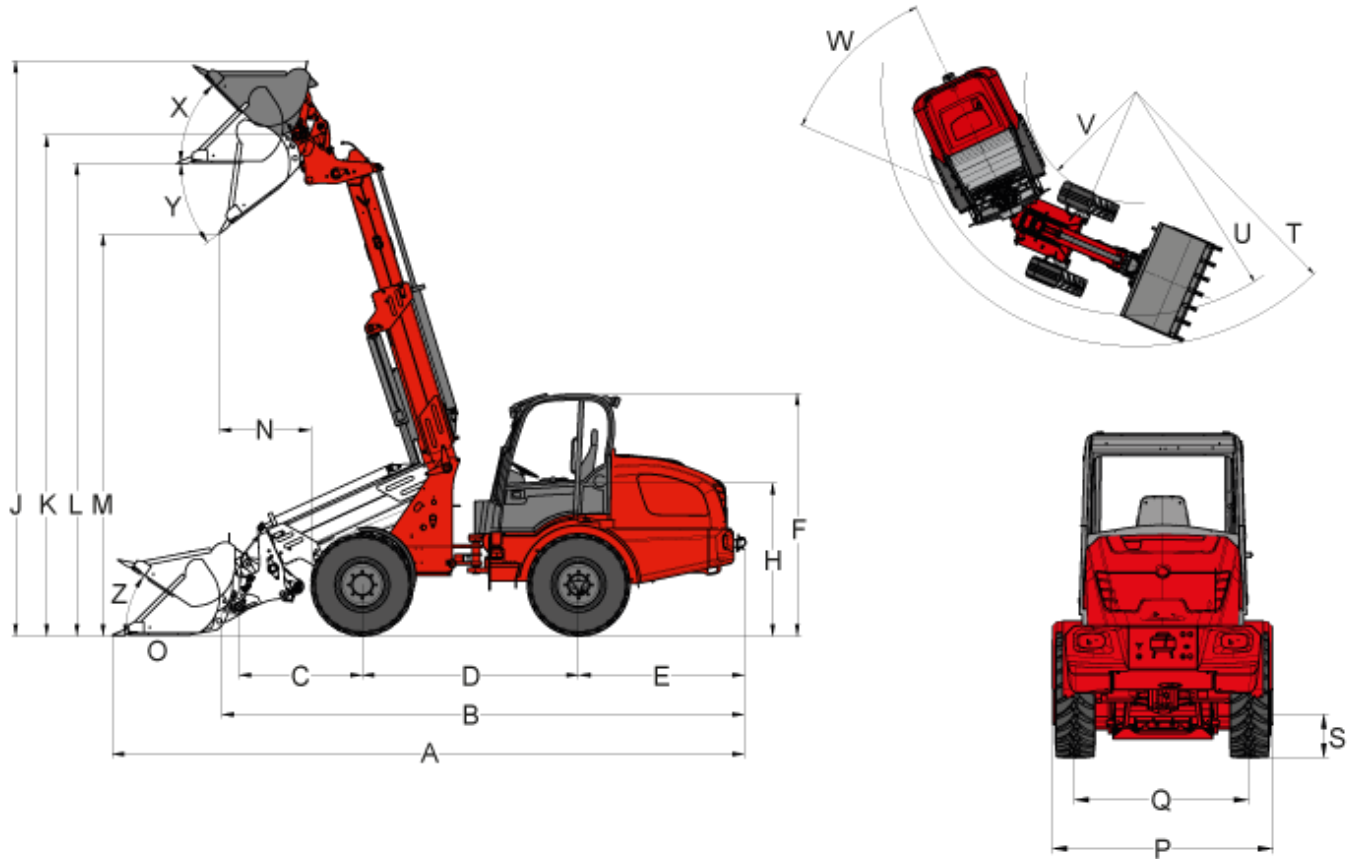

A	Total length	5,901 mm
B	Total length (without bucket)	5,135 mm
C	Axle middle to bucket pivot pin	1246 mm
D	Wheelbase	2,189 mm
E	Rear overhang	1,531 mm
F	Height to top of cabin - low-profile	2,454 mm
F	Height to top of cabin - high-profile	2,631 mm
H	Seat top height	1,518 mm
J	Total working height	5,751 mm
K	Height of bucket pivot (max.)	5,016 mm
L	Load-over height	4,572 mm
M	Dumping height	4,222 mm
N	Operating distance for M	780 mm
O	Digging depth	205 mm
P	Total width	1,580 mm
Q	Track width	1,211 mm
S	Ground clearance	323 mm

T	Maximum radius external	3,943 mm
U	Radius at the outer edge	3,461 mm
V	Inside turning radius	1,685 mm
W	Inclination angle	42 °
X	Rollback angle at max. lifting height	45 °
Y	Dumping angle (max.)	25 °
Z	Rollback angle (on the ground)	35 °

Load capacity diagram

a	757 kg
b	848 kg
c	1145 kg
d	1324 kg

## 3080T

Telescopic wheel loader

### 3080T Standard components

#### Motor

- Deutz TCD 2.9 L4 S5 (55,4 kW / 75 HP), Stage V

#### Drive system

- PA1400 planetary axle
- Hydrostatic all-wheel drive, travel direction can be selected via joystick
- Service brake: Hydrostatic drive system acting on all 4 wheels (wear-free)
- Central service and parking brake in the drive train acting on all 4 wheels
- 100% differential lock, electric-hydraulically connectable on front and rear axle
- Tires 12.5 / 80 - 18 AS ET75

#### Steering system

- Hydraulic articulated pendulum steering, 12° oscillating angle

#### Hydraulics

- 3rd control circuit front, proportionally via joystick
- Hydraulic oil cooler
- Unpressurised front reverse travel
- Floating position for lift cylinder

#### Driver's Cabin

- Comfort cabin with heater and fan, laterally tiltable, roll-over protective structure / FOPS-tested ("low" cabin height 2454 mm)
- Comfort seat with safety belt, fully suspended, weight, back and horizontal adjustment
- Hydraulic pilot operated joystick with motion direction switch and integrated touch button for differential lock and proportional telescoping function
- Adjustable steering wheel

#### Other

- Working lights (2 front, 2 rear)
- Operating hour meter
- Battery circuit breaker
- Fuel display
- Hydraulic quick-change system for attachments
- Lighting display according to Road Traffic Regulations
- Triple-pole plug receptacle in front for dual function

## 3080T

Telescopic wheel loader

### 3080T Options

#### Motor

- Engine pre-heater + hydraulic oil pre-heater 230 V

#### Drive system

- Axle PA1422
- Hand inching (creep speed controller)
- Speed increase to 30 km/h
- Load arm dampening

#### Driver's Cabin

- Comfort cabin with heater and fan, laterally tiltable, roll-over protective structure / FOPS-tested ("high" cabin height 2631 mm)
- Air-cushioned comfort seat (fabric)
- Heated seat
- Air-conditioning system
- Cabin plug receptacle 230 V
- Protective grating for windscreen
- Storage box with bottle holder

#### Lighting

- LED working lights (2 front, 2 rear)
- Rotating beacon

#### Hydraulics

- Unpressurised reverse travel (rear)
- Work hydraulics of large pump (83 l/min)
- Reversing valve in front on 3rd control circuit (3rd control circuit with 4 connections)
- Additional hydraulic oil cooler
- Faster rapid action couplings (machine and attachment-side)
- Dual-acting hydraulic connection in rear (51 l/min) proportional (two couplings) via reversing valve
- Dual-acting hydraulic connection in rear (51 l/min) (two couplings), including separate steering valve
- 2x hydraulic connection in rear (51 l/min) dual acting (four couplings), including separate steering valve

#### Electrical connections

- Front plug receptacle, 3-pole (dual function)
- Plug receptacle for rear attachments, 7-pin
- Triple-pole rear plug receptacle

#### Other

- Radio
- Reversing warning device (acoustic)
- Combination case with warning triangle and first-aid kit
- Tool kit
- Tool box
- Fire extinguisher 2kg
- Fully automatic central lubrication unit
- Hand lever grease gun
- Custommade paint finish

- Automatic trailer coupling
- Approval as self-propelled work machine with AHK\*
- Registration plate mounting
- TÜ expert's report (addendum in vehicle documentation)

\* Trailer coupling

Please note: that product availability can vary from country to country. It is possible that information / products may not be available in your country. More detailed information on engine power can be found in the operator's manual; the stated power may vary due to specific operating conditions. Subject to alterations and errors excepted. Applicable also to illustrations.  
Copyright © 2023 Weidemann GmbH.