

2080T

Telescopic wheel loader



WEIDEMANN
designed for work



2080T Technical specifications

Engine data Standard

Manufacturer	Deutz
Engine type	TD 2.9 L4 S5
Cylinders	4
Engine performance	45 (61) kW (hp)
at rpm (max.)	2300 rpm
Cubic capacity	2900 cm ³
Cooling system	Water
Emissions standard level	V
Exhaust after treatment	DPF / DOC

Engine data Optional

Manufacturer	Deutz
Engine type	TCD 2.9 L4 S5
Cylinders	4
Engine performance	55.4 (75) kW (hp)
at rpm (max.)	2300 rpm
Cubic capacity	2900 cm ³
Cooling system	Water / Charge air
Emissions standard level	V
Exhaust after treatment	DPF / DOC
Electrical system	
Operating voltage	12 V
Weights	
Operating weight (standard)	4500 / 4600* kg
Tipping load with bucket - machine straight	2632 (1507) // 3041 (1806)* kg
Tipping load with pallet fork - machine straight	2311 (1405) // 2671 (1655)* kg
Vehicle data	
Axle	PA 1200
Cab	Cabin
Ground speed (optional)	0 - 20 (28) km/h
Speed stages	2
Fuel tank capacity	75 l
Hydraulic oil tank capacity	50 l
Hydraulic system	
Steering hydraulics - Oil flow (optional)	56 (63-83) l/min
Steering hydraulics - Operating pressure	235 bar
Drive	
Type of drive	Hydrostatic
Traction drive	Universal joint shaft
Noise values	
Average sound power level L _{WA}	99.3 dB(A)
Guaranteed sound power level L _{WA}	101 dB(A)
Specified sound pressure level L _{pA}	78 dB(A)

*Values with optional Deutz engine
The values are telescoped out in () for the tipping loads

Tipping load calculation according to ISO 14397

Vibrations (weighted average effective value)

Hand-arm vibrations (HAV): The hand-arm vibrations are no more than 2.5 m/s²

Whole body vibrations: This machine is equipped with a driver's seat that meets the requirements of EN ISO 7096:2000.

When the loader is properly used, the whole body vibrations vary from below 0.5 m/s² up to a short-term maximum value.

It is recommended to use the values specified in the table when calculating the vibration values according to ISO/TR 25398:2006. At the same time the actual use conditions have to be taken into consideration.

Telescopic loaders, like wheel loaders, are to be classified by operating weight.

Type of loader	Typical operating conditions	Average value			Standard deviation (s)		
		1.4*a _{w,eqx} [m/s ²]	1.4*a _{w,eqy} [m/s ²]	a _{w,eqz} [m/s ²]	1.4*s _x [m/s ²]	1.4*s _y [m/s ²]	s _z [m/s ²]
Compact wheel loader (operating weight < 4,500 kg)	Load & carry (load and transport work)	0.94	0.86	0.65	0.27	0.29	0.13
Wheel loader (operating weight > 4,500 kg)	Load & carry (load and transport work)	0.84	0.81	0.52	0.23	0.2	0.14
	Application in extraction (harsh application conditions)	1.27	0.97	0.81	0.47	0.31	0.47
	Transfer drive	0.76	0.91	0.49	0.33	0.35	0.17
	V-operation	0.99	0.84	0.54	0.29	0.32	0.14

2080T

Telescopic wheel loader

2080T Dimensions

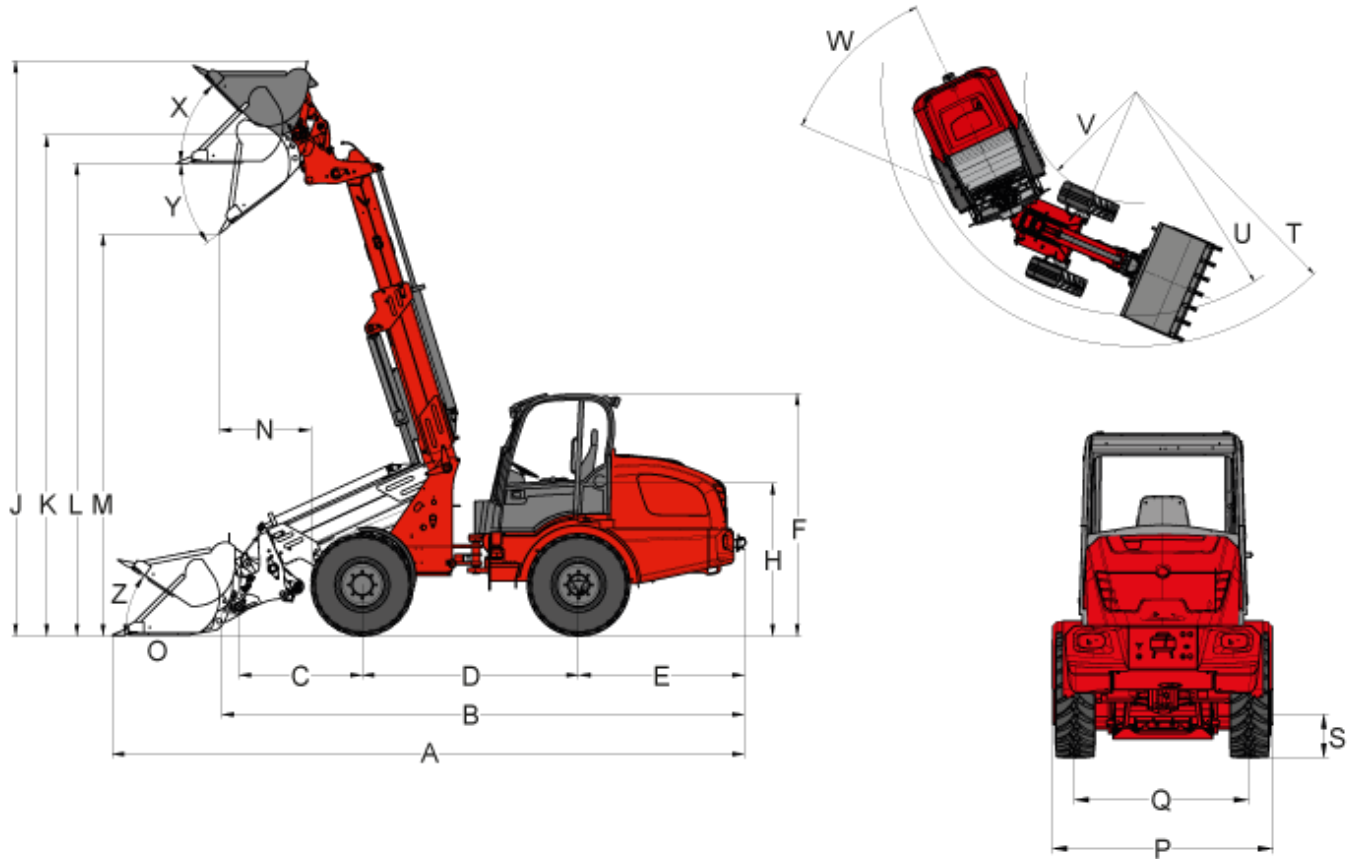

A	Total length	5,468 mm
B	Total length (without bucket)	4,689 mm
C	Axle middle to bucket pivot pin	875 mm
D	Wheelbase	2,120 mm
E	Rear overhang	1,516 mm
F	Height to top of cabin - low-profile	2,359 mm
F	Height to top of cabin - high-profile	2,535 mm
H	Seat top height	1,429 mm
J	Total working height	4,937 mm
K	Height of bucket pivot (max.)	4,292 mm
L	Load-over height	3,935 mm
M	Dumping height	3,455 mm
N	Operating distance for M	760 mm
O	Digging depth	154 mm
P	Total width	1,410 mm
Q	Track width	1,120 mm
S	Ground clearance	295 mm

T	Maximum radius external	3,761 mm
U	Radius at the outer edge	3,316 mm
V	Inside turning radius	1,727 mm
W	Inclination angle	45 °
X	Rollback angle at max. lifting height	60 °
Y	Dumping angle (max.)	35 °
Z	Rollback angle (on the ground)	37 °

Load capacity diagram

a	1163 / 1340* kg
b	892 / 1039* kg
c	702 / 828* kg

* Values with Deutz engine

2080T

Telescopic wheel loader

2080T Standard components

Motor

- Deutz TD 2.9 L4 S5 (45 kW / 61 HP), Stage V

Drive system

- PA1200 planetary axle
- Hydrostatic all-wheel drive, travel direction can be selected via joystick
- Service brake: Hydrostatic drive system acting on all 4 wheels (wear-free)
- Central service and parking brake in the drive train acting on all 4 wheels
- 100% differential lock, electric-hydraulically connectable on front and rear axle
- Tires 11.5 / 80 - 15.3 AS ET40

Steering system

- Hydraulic articulated pendulum steering, 12° oscillating angle

Hydraulics

- 3rd control circuit front, proportionally via joystick
- Hydraulic oil cooler
- Unpressurised front reverse travel
- Floating position for lift cylinder

Driver's Cabin

- Comfort cabin with heater and fan, laterally tiltable, roll-over protective structure / FOPS-tested ("low" cabin height 2359 mm)
- Comfort seat with safety belt, fully suspended, weight, back and horizontal adjustment
- Hydraulic pilot operated joystick with motion direction switch and integrated touch button for differential lock and proportional telescoping function
- Adjustable steering wheel

Other

- Working lights (2 front, 2 rear)
- Operating hour meter
- Battery circuit breaker
- Fuel display
- Hydraulic quick-change system for attachments
- Toolbox in the vehicle rear
- Lighting display according to Road Traffic Regulations
- Triple-pole plug receptacle in front for dual function

2080T

Telescopic wheel loader

2080T Options

Motor

- Deutz TCD 2.9 L4 S5 (55,4 kW / 75 PS), Stage V
- Engine pre-heater + hydraulic oil pre-heater 230 V

Drive system

- Hand inching (creep speed controller)
- Speed increase to 28 km/h
- Load arm dampening

Driver's Cabin

- Comfort cabin with heater and fan, laterally tiltable, roll-over protective structure / FOPS-tested ("high" cabin height 2535 mm)
- Air-cushioned comfort seat (fabric)
- Heated seat
- Air-conditioning system
- Cabin plug receptacle 230 V
- Storage box with bottle holder

Lighting

- LED working lights (2 front, 2 rear)
- Rotating beacon

Hydraulics

- Unpressurised reverse travel (rear)
- Work hydraulics of large pump (63 l/min)
- Work hydraulics of large pump (70 l/min)
- Work hydraulics of large pump (74 l/min)
- Reversing valve in front on 3rd control circuit (3rd control circuit with 4 connections)
- Faster rapid action couplings (machine and attachment-side)
- Additional hydraulic oil cooler
- Dual-acting hydraulic connection in rear (30 or 51 l/min) proportional (two couplings) via reversing valve
- Dual-acting hydraulic connection in rear (30 or 51 l/min) (two couplings), including separate steering valve
- 2x dual-acting hydraulic connection in rear (30 or 51 l/min) (four couplings), including separate steering valve

Electrical connections

- Front plug receptacle, 3-pole (dual function)
- Plug receptacle for rear attachments, 7-pin
- Triple-pole plug receptacle in rear

Other

- Radio
- Reversing warning device (acoustic)
- Combination case with warning triangle and first-aid kit
- Tool kit
- Fire extinguisher 2kg
- Counterweight floor plate
- Automatic trailer coupling
- Approval as self-propelled work machine with AHK*

- Fully automatic central lubrication unit
- Custommade paint finish
- Hand lever grease gun
- Registration plate mounting
- TÜ expert's report (addendum in vehicle documentation)

* Trailer coupling

Please note: that product availability can vary from country to country. It is possible that information / products may not be available in your country. More detailed information on engine power can be found in the operator's manual; the stated power may vary due to specific operating conditions. Subject to alterations and errors excepted. Applicable also to illustrations.

Copyright © 2023 Weidemann GmbH.