

2080LPT

Telescopic wheel loader



WEIDEMANN
designed for work



2080LPT Technical specifications

Engine data Standard

Manufacturer	Deutz
Engine type	TCD 2.9 L4 S5
Cylinders	4
Engine performance	45 (61) kW (hp)
at rpm (max.)	2300 rpm
Cubic capacity	2900 cm ³
Cooling system	Water
Emissions standard level	Stage V
Exhaust after treatment	DPF + DOC

Engine data Option

Manufacturer	Deutz
Engine type	TCD 2.9 L4 S5
Cylinders	4
Engine performance	55.4 (75) kW (hp)
at rpm (max.)	2300 rpm
Cubic capacity	2900 cm ³
Cooling system	Water / charge air
Emissions standard level	Stage V
Exhaust after treatment	DPF + DOC
Electrical system	
Operating voltage	12 V
Alternator	95 A
Weights	
Operating weight (standard)	4400 kg
Tipping load with bucket - machine straight (extended)	2437 - 2556 (1359 - 1437) kg
Tipping load with bucket - machine articulated (extended)	2041 - 2152 (1139 - 1219) kg
Tipping load with pallet fork - machine straight (extended)	2177 - 2266 (1287 - 1364) kg
Tipping load with pallet fork - machine articulated (extended)	1796 - 1907 (1053 - 1125) kg
Vehicle data	
Axle	PA1200
Cab (optional)	FSD (cab)
Ground speed	0-20 km/h
Speed stages	2
Fuel tank capacity	65 l
Hydraulic oil tank capacity	50 l
Hydraulic system	
External services - Operating pressure	450 bar
Steering hydraulics - Oil flow (optional)	57.5 (74) l/min
Steering hydraulics - Operating pressure	235 bar
Drive	
Type of drive	Hydrostatic
Traction drive	Universal joint shaft
Noise values	
Guaranteed sound power level L _{WA}	101 dB(A)
Specified sound pressure level L _{pA}	75 dB(A)

Tipping load calculation according to ISO 14397 (lift frame horizontal)

DPF = Diesel Particulate Filter

DOC = Diesel Oxidation Catalyst

SCR = Selective Catalytic Reduction

FSD = operator's canopy

Vibrations (weighted average effective value)

Hand-arm vibrations: The hand-arm vibrations are no more than 2.5 m/s²

Whole-body vibrations: This machine is equipped with an operator's seat that meets the requirements of EN ISO 7096:2000.

When the loader is used in accordance with the intended purpose, the whole body vibrations vary from below 0.5 m/s² up to a short-term maximum value.

It is recommended to use the values specified in the table when calculating the vibration values according to ISO/TR 25398:2006. In doing so, the actual application conditions are to be taken into consideration.

Telehandlers, like wheel loaders, are to be classified by operating weight.

Type of loader	Typical operating conditions	Mean value			Standard deviation (s)		
		1.4*a _{w,eqx} [m/s ²]	1.4*a _{w,eqy} [m/s ²]	a _{w,eqz} [m/s ²]	1.4*s _x [m/s ²]	1.4*s _y [m/s ²]	s _z [m/s ²]
Compact wheel loader (operating weight < 4,500 kg)	Load & carry (load and transport work)	0.94	0.86	0.65	0.27	0.29	0.13
Wheel loader (operating weight > 4,500 kg)	Load & carry (load and transport work)	0.84	0.81	0.52	0.23	0.2	0.14
	Application in extraction (harsh application conditions)	1.27	0.97	0.81	0.47	0.31	0.47
	Delivery drive	0.76	0.91	0.49	0.33	0.35	0.17
	V-operation	0.99	0.84	0.54	0.29	0.32	0.14

2080LPT

Telescopic wheel loader

2080LPT Dimensions

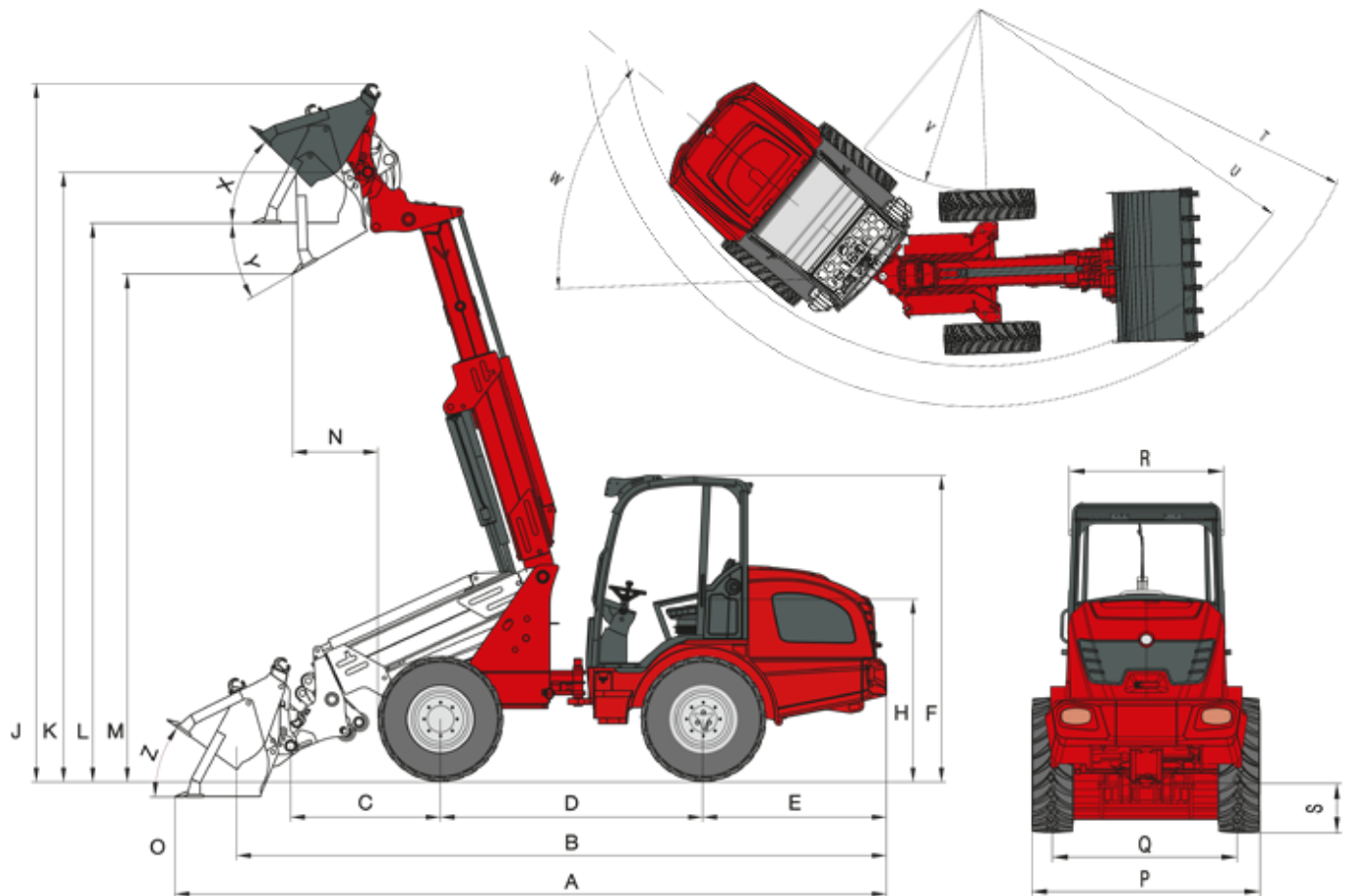

A	Total length	5,500 mm
B	Total length (without bucket)	4,630 mm
C	Axle middle to bucket pivot pin	876 mm
D	Wheelbase	2,050 mm
E	Rear overhang	1,420 mm
F	Height to top of overhead guard - low-profile	2,190 mm
	Height to top of overhead guard - high-profile	2,350 mm
	Height to top of cabin - low-profile	2,190 mm
	Height to top of cabin - high-profile	2,400 mm
H	Seat top height	1,250 mm
J	Total working height	4,954 mm
K	Height of bucket pivot (max.)	4,277 mm
L	Load-over height	3,950 mm
M	Dumping height	3,465 mm
N	Operating distance for M	878 mm
O	Digging depth	138 mm
P	Total width	1,415 mm

Q	Track width	1,132 mm
S	Ground clearance	294 mm
T	Maximum radius external	3,795 mm
U	Radius at the outer edge	3,325 mm
V	Inside turning radius	1,881 mm
W	Inclination angle	45 °
X	Rollback angle at max. lifting height	45 °
Y	Dumping angle (max.)	32 °
Z	Rollback angle (on the ground)	39 °

2080LPT

Telescopic wheel loader

2080LPT Standard components

Engine

- Deutz engine TD 2.9 L4 S5 (45 kW / 61 HP) | DPF + DOC | stage V

Steering system

- Hydraulic articulated pendulum steering, 12° oscillating angle

Tires

- 11.5/80 - 15.3 AS ET40

Drive / shaft

- Planetary axle PA1200
- Speed 20 km/h
- Hydrostatic all-wheel drive, travel direction can be selected via joystick
- Service brake: Hydrostatic drive system acting on all 4 wheels (wear-free)
- Central service and parking brake in the drive train acting on all 4 wheels
- 100 % differential lock, electric-hydraulically connectible on front and rear axle

Lighting

- Lighting according to Road Traffic Regulations (StVZO)
- Work lights, 2 in front and 2 in rear

Driver's cab

- Driver's canopy with front and rear window, roll-over protective structure/FOPS tested
- Joystick with direction control switch and integrated touch button for differential lock and telescoping function
- Adjustable steering column

Operator's seat

- Comfort seat with safety belt, fully suspended, weight, back and horizontal adjustment
- Artificial leather seat (driver's canopy)
- Fabric seat (cabin)

Hydraulics

- 3rd Front control circuit DN12
- Hydraulic oil cooler
- Unpressurised return line, front
- Floating position for lift cylinder
- Lock for steering valve

Other

- Toolbox in the vehicle rear
- Front triple-pole plug receptacle for dual function (1st function latching, 2nd function momentary)

2080LPT

Telescopic wheel loader

2080LPT Options

Driver's cab

- Overhead guard, low
- Overhead guard, high
- Tall 2-door cabin, including heater and air conditioning
- Tall 1-door cabin, including heater and air conditioning
- Radio-ready (antenna, speaker)
- Complete radio kit
- Air-conditioning system

Operator's seat

- Artificial leather seat; air cushioned
- Artificial leather seat; air cushioned; heated
- Fabric seat; air cushioned
- Fabric seat; air cushioned; heated

Lighting

- LED work lights, 2 in front, 2 in rear
- Rotating beacon (yellow)

StVZO - equipment

- Individual operating permit < 25 km/h
- Individual operating permit > 25 km/h
- Number plate bracket

Engine

- Turbo diesel engine Deutz / TCD 2.9 L4 S5 DPF / 55.4 kW (75 hp) / Exhaust emission standard: Stage V
- Manual throttle
- Engine pre-heating (coolant) + hydraulic oil pre-heating 230 V

Drive / shafts

- 28 km/h (travel speed increase)
- Hand inching (low-speed control)

Tyres

- 15.0/55-17 AS ET0
- 15.0/55-17 AS ET-40
- 425/55 R 17 AS ET-40 Alliance 570
- 31x15.50-15 EM ET-37
- 12-16.5 EM ET0
- 12-16.5 EM ET45
- 15.5/55 R 18 EM ET0
- 33x15.50-15 RP ET-37
- 12-16.5 Sure Trax ET0 BKT

Water filling

- Water filling valves without filling (front wheels)
- Water filling valves without filling (rear wheels)
- Water filling valves without filling (front and rear wheels)

- Water filling valves with filling (front wheels)
- Water filling valves with filling (rear wheels)
- Water filling valves with filling (front and rear wheels)

Loader unit

- Load arm damping

Hydraulics in front

- Work hydraulics (74 l/min) Large Pump
- Reversing valve in front on 3rd control circuit (3rd control circuit with 4 connections)
- 3. control circuit proportional, including double notch via switch
- Faster, four-fold rapid action coupling - machine-side
- Faster, four-fold rapid action couplings - attachment-side

Hydraulics in rear

- Unpressurised return line, rear
- A hydro connection in rear is dual-acting via reversing valve (l/min like 3rd control circuit in front)

Bio-hydraulic oil

- Panolin HLP Synt46 (bio-hydraulic fluid (oil))

Electrical connections in front

- Outlet in front, 3-pole for dual function (operation: Via 2 touch buttons on joystick; 1st function latching, 2nd function momentary)
- Outlet in front, 3-pole for dual function (operation: Via 2 touch buttons on joystick; 1st function momentary, 2nd function momentary)
- Outlet in front, 3-pole for dual function (operation: Via 2 touch buttons on joystick; 1st function latching, 2nd function latching)

Electrical connections in rear

- Outlet in rear, 7-pole for lighting rear attachments
- Triple-pole outlet in rear

Additional weight

- Floor plate counterweight (122 kg)

Safety options

- Reversing alarm (audible)

Other

- Circuit breaker 2 circuits
- Lever type grease press
- Combination case (warning triangle / first aid kit)
- Set of tools
- Fully automatic central lubrication unit

Custom-made paint finish

- Single colour RAL custom-made paint finish - instead of Weidemann red
- Custom-made paint finish RAL multi-colour

Coupling and retrieval devices

- Automatic trailer coupling

Self-propelled work machine with trailer coupling

- Automatic trailer coupling

Please note: that product availability can vary from country to country. It is possible that information / products may not be available in your country. More detailed information on engine power can be found in the operator's manual; the stated power may vary due to specific operating conditions. Subject to alterations and errors excepted. Applicable also to illustrations.
Copyright © 2023 Weidemann GmbH.