

1390 Hoftrac



WEIDEMANN
designed for work



1390 Technical specifications

Engine data Standard

Manufacturer	Yanmar
Engine type	3TNV80FT
Cylinders	3
Engine performance	18.4 (25) kW (hp)
at rpm (max.)	2600 rpm
Cubic capacity	1226 cm ³
Cooling system	Water
Emissions standard level	V
Exhaust after treatment	-

Engine data Optional

Manufacturer	Yanmar
Engine type	3TNV86CHT
Cylinders	3
Engine performance	33.3 (45.3) kW (hp)
at rpm (max.)	2600 rpm
Cubic capacity	1568 cm ³
Cooling system	Water
Emissions standard level	V
Exhaust after treatment	DOC+DPF
Engine data Optional	
Manufacturer	Yanmar
Engine type	3TNV86CHT
Cylinders	3
Engine performance	40.1 (54.5) kW (hp)
at rpm (max.)	2600 rpm
Cubic capacity	1568 cm ³
Cooling system	Water
Emissions standard level	V
Exhaust after treatment	DOC+DPF
Electrical system	
Operating voltage	12 V
Battery	77 Ah
Alternator	80 A
Weights	
Operating weight (standard)	2750-3200* kg
Tipping load with bucket - machine straight	1610-2100* kg
Tipping load with bucket - machine articulated	1340-1790* kg
Tipping load with pallet fork - machine straight	1560-1950* kg
Tipping load with pallet fork - machine articulated	1310-1680* kg
Vehicle data	
Axle (optional)	T94 (PA940)
Cab (optional)	FSD (eps, cabin)
Ground speed (optional)	0-20 (30) km/h
Speed stages	2
Fuel tank capacity	50 l
Hydraulic oil tank capacity	30 l
Hydraulic system	
External services - Operating pressure (optional)	380 (450) bar
Steering hydraulics - Oil flow (optional)	41.6 (49.5-84) l/min
Steering hydraulics - Operating pressure	210 bar
Drive	

Type of drive	ecDrive (electronically-controlled traction drive)
Traction drive	hydrostatic via Transfer gear driveshaft
Noise values	
Average sound power level LwA	99 dB(A)
Guaranteed sound power level LwA	101 dB(A)
Specified sound pressure level LpA	84 dB(A)

* With optional equipment (large engine, cab, etc.)

Tipping load calculation according to ISO 14397 (lift frame horizontal)

DPF (diesel particulate filter)

DOC (diesel oxidation catalytic converter)

FSD = overhead guard

Vibrations (weighted average effective value)

Hand-arm vibrations: The hand-arm vibrations are no more than 2.5 m/s²

Whole-body vibrations: This machine is equipped with an operator's seat that meets the requirements of EN ISO 7096:2000.

When the loader is used in accordance with the intended purpose, the whole body vibrations vary from below 0.5 m/s² up to a short-term maximum value.

It is recommended to use the values specified in the table when calculating the vibration values according to ISO/TR 25398:2006. At the same time, the actual use conditions have to be taken into consideration.

Telehandlers, like wheel loaders, are to be classified by operating weight.

Type of loader	Typical operating conditions	Mean value			Standard deviation (s)		
		$1,4 \cdot a_{w,eqx}$ [m/s ²]	$1,4 \cdot a_{w,eqy}$ [m/s ²]	$a_{w,eqz}$ [m/s ²]	$1,4 \cdot s_x$ [m/s ²]	$1,4 \cdot s_y$ [m/s ²]	s_z [m/s ²]
Compact wheel loader (Operating weight < 4500kg)	Load & carry (loading and transport work)	0.94	0.86	0.65	0.27	0.29	0.13
Wheel loader (Operating weight > 4500kg)	Load & carry (loading and transport work)	0.84	0.81	0.52	0.23	0.2	0.14
	Application in extraction (harsh application conditions)	1.27	0.97	0.81	0.47	0.31	0.47
	Delivery drive	0.76	0.91	0.49	0.33	0.35	0.17
	V-operation	0.99	0.84	0.54	0.29	0.32	0.14

1390 Dimensions

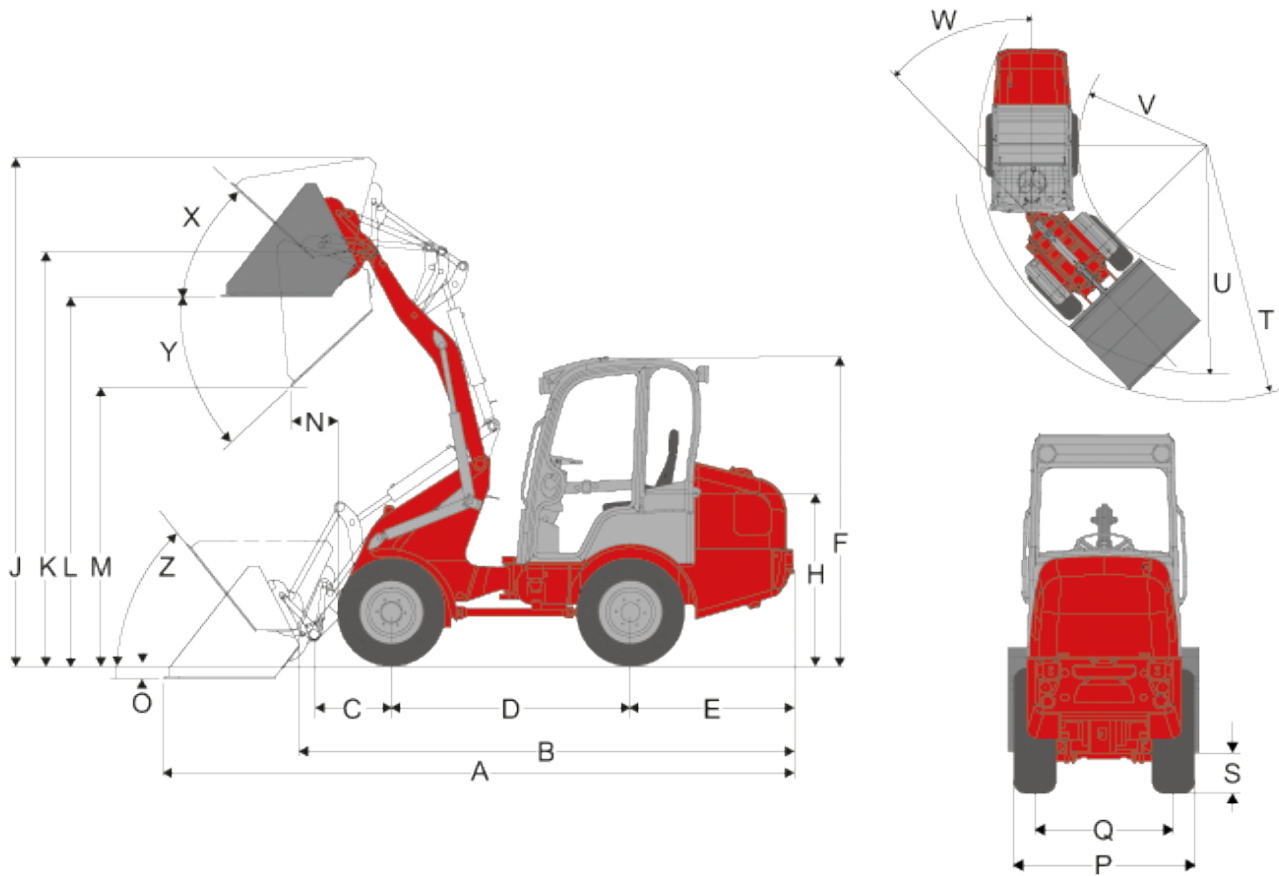

Variant		P-kinematics (standard)	P-kinematics (long)	PZ-kinematics
Standard tyres		10.0/75 - 15.3 AS ET80	10.0/75 - 15.3 AS ET80	10.0/75 - 15.3 AS ET80
A	Total length	4,470 mm	4,820 mm	4,630 mm
B	Total length (without bucket)	3,570 mm	3,910 mm	3,730 mm
C	Axle middle to bucket pivot pin	603 mm	878 mm	720 mm
D	Wheelbase	1,732 mm	1,732 mm	1,732 mm
E	Rear overhang	1,230 mm	1,230 mm	1,230 mm
F	Height to top of overhead guard fixed	2,320 mm	2,320 mm	2,320 mm
Height to top of cabin				

		2,340 mm	2,340 mm	2,340 mm
H	Seat top height	1,330 mm	1,330 mm	1,330 mm
J	Total working height	3,660 mm	3,930 mm	3,830 mm
K	Height of bucket pivot (max.)	3,004 mm	3,200 mm	3,200 mm
L	Load-over height	2,680 mm	2,880 mm	2,880 mm
M	Dumping height	2,120 mm	2,330 mm	2,380 mm
O	Digging depth	80 mm	130 mm	127 mm
P	Total width	1,124 mm	1,124 mm	1,124 mm
Q	Track width	780 mm	780 mm	780 mm
S	Ground clearance	250 mm	250 mm	250 mm
T	Maximum radius external	3,000 mm	3,150 mm	3,340 mm
U	Radius at the outer edge	2,710 mm	2,710 mm	2,980 mm
V	Inside turning radius	1,560 mm	1,560 mm	1,850 mm
W	Inclination angle	45 °	45 °	40 °
X	Rollback angle at max. lifting height	42 °	65 °	57 °
Y	Dumping angle (max.)	43 °	42 °	37 °
Z	Rollback angle (on the ground)	51 °	56 °	50 °

1390

Hoftrac

1390 Standard components

Engine

- Yanmar 3TNV80FT; Stage V (18.4 kW / 25 hp)

Steering system

- Hydraulic articulated pendulum steering

Driver's cab

- Overhead guard with retaining system ROPS / FOPS tested, driver's cab can be tilted to the side
- Generous space provision in all drivers' cabs
- Ergonomically generous entry
- Adjustable steering column (tilt and height)
- LED working lights (1000 lm) on overhead guard, 2 at the front, 1 at the rear

Driver's seat

- Comfort seat with safety belt, fully suspended, weight, back and horizontal adjustment

Lighting

- LED work lights, 2 front, 1 rear on the overhead guard

Drive / axles

- T94 axle
- Drive: hydrostatic through PTO gear and driveshaft, electronically controlled (medium pressure all-wheel steering)
- Drive modes: Auto mode, eco mode (reduced rpm once set speed is reached)
- Speed: 20 km/h
- Speed stages: 2 | 7 km/h / 20 km/h (optional 30 km/h)
- Service brake: Multi-disc brake on the front axle acts on rear axle through driveshaft
- Parking brake: Electro-hydraulic multi-disc brake with spring accumulator on the front axle acts on the rear axle through driveshaft, including hill-hold function

Tyres

- 10.0/7515.3 AS ET40

Loader unit

- Load arm lifting height 3040 mm
- Quickhitch facility (Weidemann HV/ HT - C) hydraulic
- Kinematics: P
- Lifting cylinder: 2
- Tilting cylinder: 1

Hydraulics

- Mechanical pilot-operated joystick with forward-reverse control switch
- 3rd Front control circuit via lever with simple joystick for continuous function

Other

- Weight of cast iron rear

1390

Hoftrac

1390 Options

Driver's cab

- Fold-down overhead guard eps ROPS/FOPS tested
- Cab 2 one-piece doors
- Cab 2 two-piece doors
- Front and rear heated rear window including front and rear windscreen wipers (for overhead guard)
- Faux-leather seat; air cushioned
- Faux leather seat; air cushioning; heated seat
- Fabric seat (standard for cab)
- Fabric seat; air cushioning
- Fabric seat; air cushioning; heated
- Air-conditioning system
- Radio-ready (antenna, speaker)
- Complete radio kit
- Sun shade

Lighting

- Lighting according to Road Traffic Regulations (StVZO)
- LED lighting according to Road Traffic Regulations (StVZO)
- LED Performance working lights (2000 lm) on overhead guard, 2 at the front, 2 at the rear
- Provision for rotating beacon
- Rotating LED beacon (yellow) (must comply with national specifications!)
- Rotating beacon (yellow) with magnetic base (must comply with national specifications!)

Permitted on public highways

- Individual operating permit < 25 km/h
- Individual operating permit > 25 km/h
- Tractor tool carrier
- Front and rear licence plate bracket
- Warning markings (DIN 30710)
- Triangular warning plate
- Warning markings + triangular warning plate

Drive system

- Diesel engine Yanmar 3TNV86, Stage V (33.3 kW / 45 hp)
- Diesel engine Yanmar 3TNV86, Stage V (40.1 kW / 54.5 hp)
- Manual throttle
- Engine pre-heater (coolant) + hydraulic oil pre-heater 230 V

Axles

- PA940 planetary axle, hydrostatic medium pressure all-wheel steering, 18 km/h (30 km/h), PTO gear, driveshaft, differential lock 100%
- Planetary axle, PA940 planetary axle, hydrostatic high pressure all-wheel steering, 18 km/h (30 km/h), PTO gear, driveshaft, differential lock 100%

Drive mode

- Drive mode auto / eco / attachments
- Drive mode auto / eco / M-drive

Driving speed

- 30 km/h (speed increase)
- Proportional speed limiter (slow speed facility)

Tyres

- [See here»](#)

Loader unit

- P-kinematics lifting height (3200 mm)
- PZ-kinematics lifting height (3200 mm)
- Lowering brake valve (hose burst valve for lift and tipping cylinders)
- Load arm damping
- Switch position indicator

Quickhitch plates

- Weidemann HV/HT - C - ECS (hydraulic - easy coupler system)
- Euro (hydraulic - ISO23206 EURO HV) (incl. two couplings SVK Gr. 3)
- SkidSteer (hydraulic - SAEJ2513 SSL HV)
- SMS HV (hydraulic)
- Kramer HV/WL - C (hydraulic)

Hydraulics in front

- 3rd control circuit proportional, including continuous function via switch, pressure release for 3rd control circuit front on the loader unit, oil volume adjustment, operation: via wheel on the front of the joystick
- 4th control circuit, proportionally, serial (comprises: 3rd control circuit proportional), operation: via wheel on top of the joystick
- Work hydraulics (58.5 l/min) large pump
- High flow single-acting performance hydraulics (84 l/min) (two couplings 1 x flat face Gr. 4A, plug / 1x flat face Gr. 4A, bushing),
- Unpressurised return line (1 x flat face Gr.3, plug) including overflow oil line (1 x flat face Gr. 2, plug)
- Quick-connect couplings (Faster) 2-way - equipment side
- Quick-connect couplings (Faster) 2-way - equipment side + attachment side
- Quick-connect couplings (Faster) 2x 2-way - equipment side
- Quick-connect couplings (Faster) 2x 2-way - equipment side + attachment side

Hydraulics at rear

- One hydro connection at rear (dual acting) via reversing valve (two SVK couplings Gr. 3), (3rd control unit front or rear), operation: via switch (0 - 1) + 3rd control circuit
- Two hydro connections at rear (dual acting) (4 SVK couplings Gr. 3) incl. separate control valve (25 l/min), operation: via 2 switch (1 - 0 - 2)
- Unpressurised return line rear (1 x flat face Gr.3, plug) including overflow oil line (1 x flat face Gr. 2, plug)
- Panolin HLP Synt46 (bio-hydraulic fluid (oil))

electrical system

- Additional control unit
- Battery cut-off switch 2 circuits (disconnection of on-board voltage supply and generator via 2 feed paths from battery)

Electrics front

- Socket front 13-pole (2x electrical functions E1/E2 and lighting), operation: Via 2 touch buttons on joystick; 1st function momentary, 2nd function latching
- Socket front 13-pole (2x electrical functions E1/E2 and lighting), operation: Via 2 touch buttons on joystick; 1st function latching, 2nd function momentary
- Socket front 13-pole (2x electrical functions E1/E2 and lighting), operation: Via 2 touch buttons on joystick; 1st function

momentary, 2nd function momentary

- Socket front 13-pole (2x electrical functions E1/E2 and lighting), operation: Via 2 touch buttons on joystick; 1st function latching, 2nd function latching

Electric rear

- Triple-pole socket at rear (2x electrical functions E3/ E4, may be switched to socket at front), operation: Via switch; 1st function latching, 2nd function latching
- Socket at rear, 7-pole for lighting rear attachments

Safety options

- Reversing warning (audible)
- KAT drive interlock, operation: via coded ignition switch key

Other

- Ball hitch device K50
- Automatic hitch device
- Ballast weight floor plate (100 kg)
- Ballast weight floor plate (180 kg)
- Toolbox incl. tool set and hand lever grease gun
- Combination box (for combination bag)
- Combination bag (warning triangle / first aid kit)
- Fully automatic central lubrication unit
- Single colour RAL custom paint finish - instead of Weidemann red
- Multicolour RAL custom paint finish
- Self-propelled work machine with trailer coupling; only in connection with: Automatic hitch device, lighting according to Road Traffic Regulations (StVZO), rear 7-pole socket for lighting rear attachments, individual operating permit

Please note: that product availability can vary from country to country. It is possible that information / products may not be available in your country. More detailed information on engine power can be found in the operator's manual; the stated power may vary due to specific operating conditions. Subject to alterations and errors excepted. Applicable also to illustrations.

Copyright © 2022 Weidemann GmbH.